

# VENT-FREE FIREPLACE SYSTEMS

## INSTALLATION AND OPERATING INSTRUCTIONS

### MODELS

DFX24

DBX24\*

DFX32

Natural Gas or

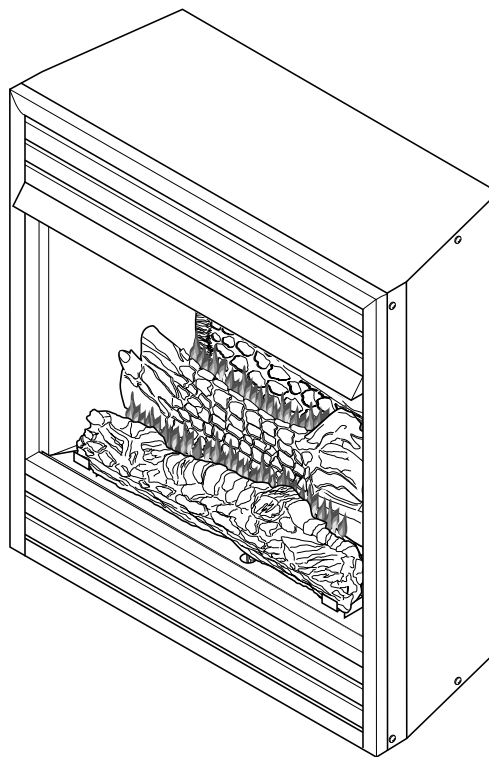
Propane/LPG

Manual, Milli-Volt,

or

Thermostat Control

\*Thermostat Control Only



This is an unvented gas-fired heater. It uses air (oxygen) from the room in which it is installed. Provisions for adequate combustion and ventilation air must be provided. Refer to page 9.

## WARNINGS

If the information in this manual is not followed exactly, a fire or explosion may result causing property damage, personal injury or loss of life.

- Do not store or use gasoline or other flammable vapors and liquids in the vicinity of this or any other appliance.
- **WHAT TO DO IF YOU SMELL GAS**
  - Do not try to light any appliance.
  - Do not touch any electrical switch; do not use any phone in your building.
  - Immediately call your gas supplier from a neighbor's phone. Follow the gas supplier's instructions.
  - If you cannot reach your gas supplier, call the fire department.
- Installation and service must be performed by a qualified installer, service agency or the gas supplier.

**READ AND SAVE THESE INSTRUCTIONS**

---

# CONTENTS

---

IMPORTANT SAFETY INFORMATION .....	3
PRODUCT FEATURES .....	5
PRODUCT FEATURES and SPECIFICATIONS .....	6
GETTING STARTED .....	7
GENERAL INSTALLATION INFORMATION .....	8
LOCATION OF FIREPLACE .....	16
CLEARANCES and HEIGHT REQUIREMENTS .....	17
FIREPLACE FRAMING .....	18
CONNECTING THE GAS .....	20
CHECKING GAS PRESSURE .....	21
ELECTRICAL WIRING (MILLI-VOLT) .....	22
LOG PLACEMENT .....	24
FLAME APPEARANCE .....	26
CHECKING THE BURNER FLAME .....	27
OPERATING INSTRUCTIONS .....	29
FOR YOUR SAFETY READ BEFORE LIGHTING .....	29
MANUAL CONTROL LIGHTING INSTRUCTIONS .....	30
THERMOSTATIC CONTROL LIGHTING INSTRUCTIONS .....	31
MILLI-VOLT CONTROL LIGHTING INSTRUCTIONS .....	32
MATCH LIGHTING INSTRUCTIONS .....	33
CLEANING and SERVICING .....	33
BLOWER AND OTHER OPTIONAL EQUIPMENT .....	34
ILLUSTRATED PARTS BREAKDOWN AND CABINET ACCESSORIES .....	35
ILLUSTRATED PARTS BREAKDOWN (DFX24 MILLI-VOLT, DFX24 MANUAL, DFX24 T-STAT) .....	36
REPLACEMENT PARTS LIST (DFX24 MILLI-VOLT, DFX24 MANUAL, DFX24 T-STAT) .....	37
ILLUSTRATED PARTS BREAKDOWN (DFX32 MILLI-VOLT, DFX32 MANUAL, DFX32 T-STAT) .....	38
REPLACEMENT PARTS LIST (DFX32 MILLI-VOLT, DFX32 MANUAL, DFX32 T-STAT) .....	39
ILLUSTRATED PARTS BREAKDOWN (DBX24 T-STAT) .....	40
REPLACEMENT PARTS LIST (DBX24 T-STAT) .....	41
TROUBLESHOOTING .....	42
WARRANTY .....	BACK COVER

## IMPORTANT SAFETY INFORMATION

### INSTALLER

Please leave these instructions with the owner.

### OWNER

Please retain these instructions for future reference.

### IMPORTANT

Read these instructions carefully before installing or trying to operate this vent-free gas heater.

### WARNING

- Any change to this heater or its controls can be dangerous.
- Improper installation or use of the heater can cause serious injury or death from fire, burns, explosion or carbon monoxide poisoning.
- Do not allow fans to blow directly into the fireplace. Avoid drafts that alter burner flame patterns.
- Do not use a blower insert, heat exchanger insert or other accessory, not approved for use with this heater.

1. Due to high temperatures, the heater should be located out of traffic and away from furniture and draperies.
2. Children and adults should be alerted to the hazard of high surface temperature and should stay away to avoid burns or clothing ignition.
3. Young children should be carefully supervised when they are in the same room with the heater
4. Do not place clothing or other flammable material near the fireplace when the heater is in use.
5. Any safety screen or guard removed for servicing must be replaced prior to operating the heater.
6. Installation and repair should be done by a qualified service person.
7. To prevent malfunction and/or sooting, an unvented gas heater should be cleaned at least annually by a professional service person. More frequent cleaning may be required due to excessive lint from carpeting, etc. It is imperative that control compartments, burners and circulating air passageways be kept clean.
8. **CARBON MONOXIDE POISONING:** Early signs of carbon monoxide poisoning are similar to the flu with headaches, dizziness and/or nausea. If you have these signs, obtain fresh air immediately. Have the heater serviced as it may not be operating properly.
9. The installation must conform with local codes or, in the absence of local codes, with the National Fuel Gas Code, ANSI Z223.1.
10. This unit complies with ANSI Z21.11.2b-1998 Unvented Heaters. State and local codes may only allow operation of this appliance in a vented configuration. Check your state or local codes.
11. Do not install the DFX Model in a bathroom or bedroom. The DBX Model may be installed in a bedroom, but not in a bathroom.
12. Correct installation of the ceramic fiber logs, proper location of the heater, and annual cleaning are necessary to avoid potential problems with sooting. Sooting, resulting from improper installation or operation, can settle on surfaces outside the fireplace. See log placement instructions for proper installation.
13. Avoid any drafts that alter burner flame patterns. Do not allow fans to blow directly into fireplace. Do not place a blower inside burn area of firebox. Ceiling fans may create drafts that alter burner flame patterns. Sooting and improper burning will occur.
14. This is an unvented gas-fired heater. It uses air (oxygen) from the room in which it is installed. Provisions for adequate combustion and ventilation air must be provided. Refer to Page 9.
15. Keep appliance area clear and free from combustible materials, gasoline and other flammable vapors and liquids.
16. Unvented gas heaters are a supplemental zone heater. They are not intended to be a primary heating appliance. Water vapor produced by an unvented heater can create moisture problems in a home when operated for extended periods of time.

---

## IMPORTANT SAFETY INFORMATION

---

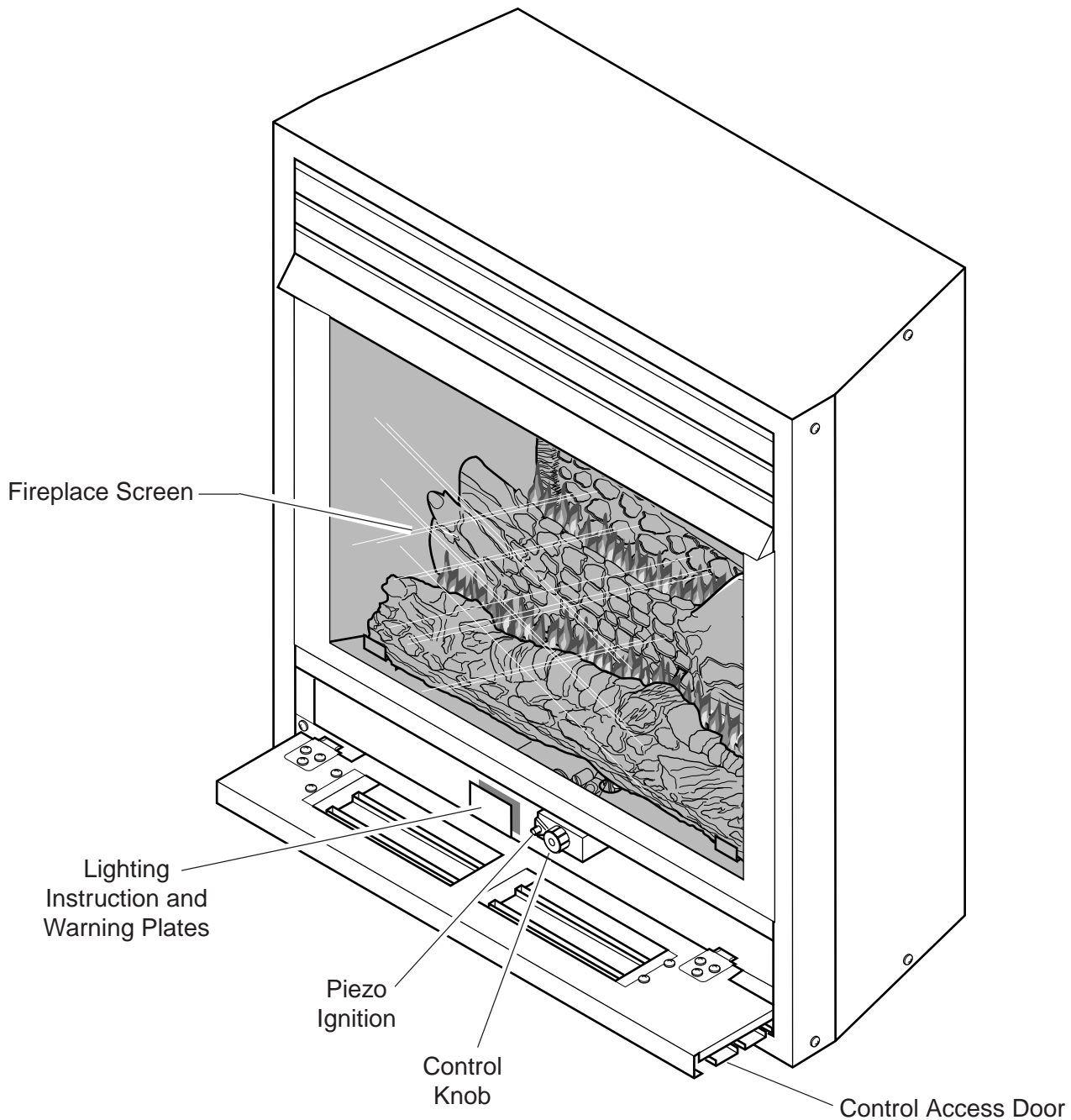
17. During manufacturing, fabricating and shipping, various components of this appliance are treated with certain oils, films or bonding agents. These chemicals are not harmful but may produce annoying smoke and smells as they are burned off during the initial operation of the appliance, possibly causing headaches or eye or lung irritation. This is a normal and temporary occurrence.

The initial break-in operation should last two to three hours with the burner at the highest setting. Provide maximum ventilation by opening windows or doors to allow odors to dissipate. Any odors remaining after this initial break-in period will be slight and will disappear with continued use.

18. Input ratings are shown in BTU per hour and are for elevations up to 2,000 feet. For elevations above 2,000 feet, input ratings should be reduced 4 percent for each 1,000 feet above sea level. Refer to the National Fuel Gas Code.
19. The appliance and its appliance main gas valve must be disconnected from the gas supply piping system during any pressure testing of that system at test pressures in excess of 1/2 psig (3.5 kPa).
20. The appliance must be isolated from the gas supply piping system by closing its equipment shutoff valve during any pressure testing of the gas supply piping system at test pressures equal to or less than 1/2 psig (3.5 kPa).
21. Do not use this room heater if any part has been under water. Immediately call a qualified service technician to inspect the room heater and to replace any part of the control system and any gas control which has been under water.
22. This appliance must not be used with glass doors in the closed position. This can lead to pilot outages and severe sooting outside the fireplace.
23. Never burn solid fuels in a fireplace where a unvented room heater is installed.
24. Always have a fireplace screen in place when the appliance is in operation and, unless other provisions for combustion air are provided, the screen shall have an opening(s) for induction of combustion air.

**This appliance may be installed in an aftermarket, permanently located, manufactured (mobile) home, where not prohibited by local codes.**

**This appliance is only for use with the type of gas indicated on the rating plate. This appliance is not convertible for use with other gases.**



***Figure 1 - Unvented Gas Heater  
(Control Access Door Shown Open)***

Your vent-free fireplace must be mounted on the floor or on the optional fireplace hearth.

## **OPERATION**

This unvented gas heater requires no outside venting and burns cleanly with high heating efficiency.

This zero-clearance unvented gas heater can be installed against (or recessed into) any wall that is accessible to a gas line.

## PRODUCT FEATURES and SPECIFICATIONS

### NATURAL GAS

#### Manual Pressure/T-Stat

Regulator Pressure Setting: 3 in. w.c.  
 Gas Inlet Pressure: Max. 10.5 in. w.c.  
 Min. 5 in. w.c.

#### Milli-Volt Pressure

Regulator Pressure Setting: 3.5 in. w.c.  
 Pilot Regulator: 3.5 in. w.c.  
 Gas Inlet Pressure: Max. 10.5 in. w. c.  
 Min. 5 in. w.c.

Model Number	Type	Gas Rate		Number of Burners
		Max BTU/Hr	Min BTU/Hr	
DFX24NM	Manual	22,000	11,000	2
DFX24NT	T-stat	22,000	17,000	2
DFX24NV	Milli-Volt	22,000	17,000	2
DBX24NT	T-stat	10,000	N/A	1
DFX32NM	Manual	26,000	15,000	2
DFX32NT	T-stat	26,000	20,000	2
DFX32NV	Milli-Volt	26,000	20,000	2

### Propane / LPG

**Note: An external regulator is required to reduce supply pressure to a maximum of 13" w. c.**

#### Manual Pressure

Regulator Pressure Setting: 10 in. w.c.  
 Gas Inlet Pressure: Maximum 13 in. w.c.  
 Minimum 11 in. w.c.

#### Milli-Volt Pressure

Regulator Pressure Setting: 10 in. w.c.  
 Gas Inlet Pressure: Maximum 13 in." w.c.  
 Minimum 11 in. w.c.

Model Number	Type	Gas Rate		Number of Burners
		Max BTU/Hr	Min BTU/Hr	
DFX24PM	Manual	22,000	11,000	2
DFX24PT	T-stat	22,000	17,000	2
DFX24PV	Milli-Volt	22,000	17,000	2
DBX24PT	T-stat	10,000	N/A	1
DFX32PM	Manual	26,000	15,000	2
DFX32PT	T-stat	26,000	20,000	2
DFX32PV	Milli-Volt	26,000	20,000	2

### IGNITION CONTROLS

Piezo ignitor allows ignition of the pilot without the use of matches or batteries.

#### Manual control has four (4) positions:

- OFF** - All gas to the gas logs is shut off at the valve.
- IGN** - Valve position to light/maintain a standing pilot.
- LOW** - Minimum gas rate — front burner provides a realistic glow on the center log.
- HI** - Maximum gas rate — front burner provides a realistic glow on the center log, plus the rear burner provides a pleasing yellow flame.

---

## PRODUCT SPECIFICATIONS and GETTING STARTED

---

### Thermostat control has three (3) positions:

- OFF** - All gas to the gas logs is shut off at the valve.
- IGN** - Valve position to light/maintain a standing pilot.
- LOW/HI** - Variable position corresponding to desired temperature.

### Milli-Volt control has four (4) positions:

- OFF** - All gas to the gas logs is shut off at the valve.
- IGN** - Valve position to light/maintain a standing pilot.
- ON** - Valve position to turn ON/OFF log set with remote switch/thermostat.
- LOW/HI** - Variable position to control flame height (heat output). Both front and rear burners are in operation to provide realistic glow and yellow flame.

### PILOT

The gas log heater is fitted with a specially designed safety pilot light which senses the amount of oxygen available in the room and shuts the gas log heater off if the oxygen level begins to drop below a satisfactory level. The pilot can only be relit when adequate fresh air is available.

### THERMAL GENERATOR

The milli-volt gas log pilot is fitted with a milli-volt generator to provide power for remote activation.

### GETTING STARTED

Make sure you have received all parts:

Check your packing list to verify that all listed parts have been received. You should have the following:

- Unvented gas heater
- Installation/operating instructions
- Ceramic fiber logs
- Two (2) 90°-angle brackets
- Canopy and three (3) screws
- One (1) plastic grommet
- Trim kit
- Two (2) anchoring screws
- Four (4) brass screws

Millivolt controlled heater designed to be operated with optional devices for ON/OFF functions.

- Hand held Remote with receiver
- Wall T-stat with 20' wire
- Wall switch with 20' wire
- Hand held Thermostat Remote w/receiver

### CAUTION

- **Handle the gas log burner assembly by the grate only. Do not pick the unit up by the burners.**
- **Gloves are recommended when handling ceramic fiber logs to prevent skin irritation from loose fibers. Logs are fragile — handle with care.**

Carefully inspect the contents for shipping damage. If any parts are missing or damaged, immediately inform the dealer from whom you purchased the appliance. **Do not attempt to install any part of the appliance unless you have all parts in good condition.**

What you will need for installation:

You must have the following items available before proceeding with installation:

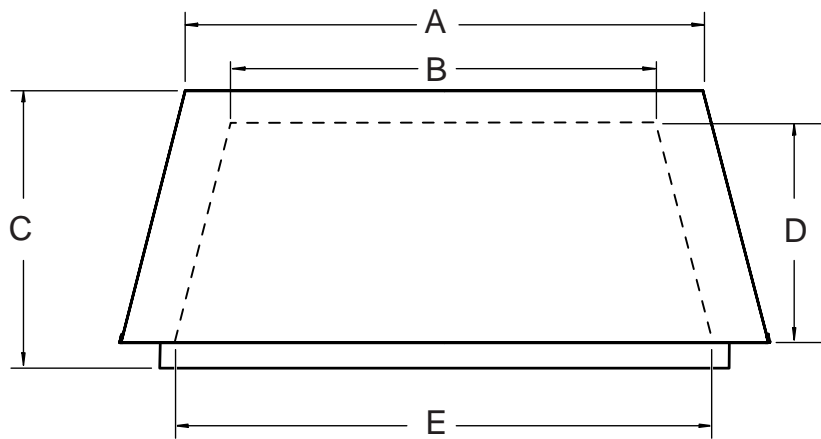
- External regulator (for propane/LPG only)
- Piping which complies with local codes
- Phillips head screwdriver
- Pipe sealant approved for use with propane/LPG (Resistant to sulfur compounds)
- Manual shutoff valve
- Sediment trap
- Tee joint.
- Pipe wrench



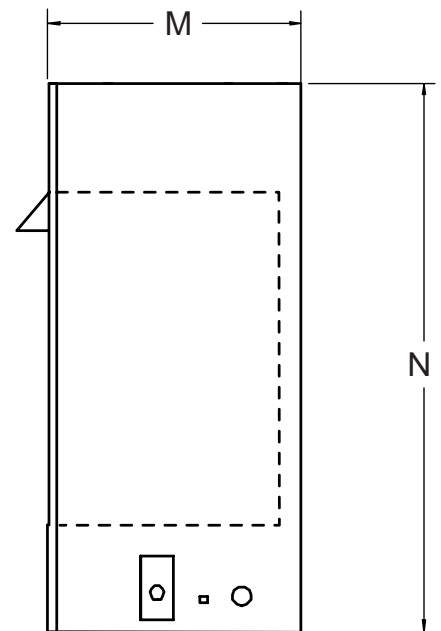
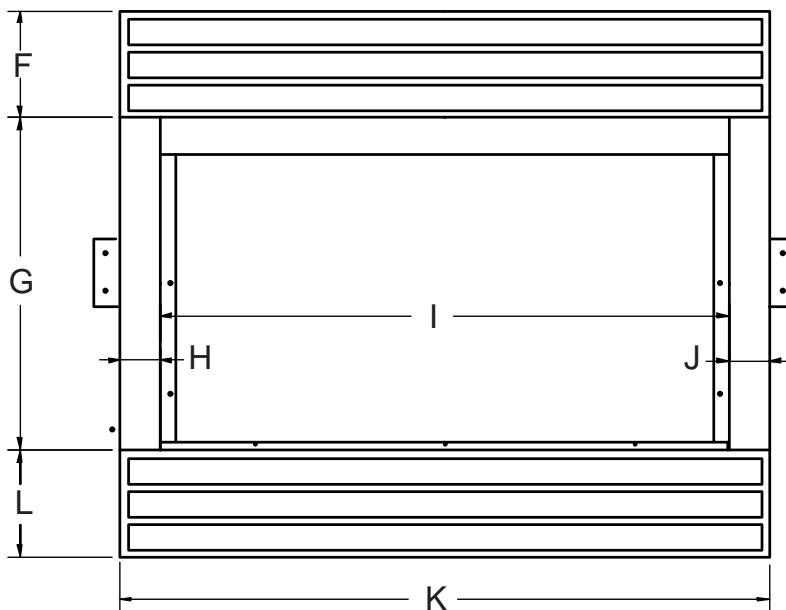
# GENERAL INSTALLATION INFORMATION

In planning the installation for the fireplace it is necessary to determine where the unit is to be installed and whether optional accessories are desired. Gas supply piping should also be planned. The following steps represent the normal sequence of installation. Each installation is unique, however, and might require a different sequence.

1. Position fireplace in desired location. Refer to the “LOCATION OF FIREPLACE” and “CLEARANCES and HEIGHT REQUIREMENTS”, and “FIREBOX FRAMING” sections found in this manual. *Note: Be sure all packing material has been removed from underside the unit.*
2. Install canopy and logs per instructions found in this manual. The canopy **MUST** be installed for safe operation of the unit.
3. Field wire main power supply to units with fan kit. Refer to the “ELECTRICAL SECTION” found in this manual. (Electrical connections should only be performed by an experienced, licensed certified tradesman).
4. Install optional ON/OFF kit on units with millivolt control. Refer to installation instructions included with the kit and also refer to the “ELECTRICAL WIRING” section found in this manual.
5. Plumb gas line. Refer to the “CONNECTING THE GAS” section found in this manual. (Gas connections should only be performed by an experienced, licensed / certified tradesman).
6. Complete finish wall material and/or surround.



	DFX24/DBX24	DFX32
A	21 <sup>1</sup> / <sub>2</sub>	29
B	18	19
C	11 <sup>1</sup> / <sub>2</sub>	12 <sup>1</sup> / <sub>2</sub>
D	10	11
E	20 <sup>3</sup> / <sub>4</sub>	27
F	5	5
G	16 <sup>1</sup> / <sub>2</sub>	18 <sup>3</sup> / <sub>4</sub>
H	1	1 <sup>3</sup> / <sub>4</sub>
I	22 <sup>1</sup> / <sub>2</sub>	28 <sup>1</sup> / <sub>2</sub>
J	1	1 <sup>3</sup> / <sub>4</sub>
K	24 <sup>1</sup> / <sub>2</sub>	32
L	5 <sup>1</sup> / <sub>2</sub>	6 <sup>1</sup> / <sub>4</sub>
M	10 <sup>1</sup> / <sub>2</sub>	12
N	26 <sup>1</sup> / <sub>2</sub>	32



**Figure 2 - Firebox Dimensions with Screen and Log Sets Removed**



### CODES

Adhere to all local codes or, in their absence, the latest edition of THE NATIONAL FUEL GAS CODE ANSI Z223.1 or NFPA54 which can be obtained from...

**American National Standards Institute, Inc.**

1430 Broadway  
New York, NY 10018

or

**National Fire Protection Association, Inc.**

Batterymarch Park  
Quincy, MA 02269

**WARNING**

**Do not install the heater**

- **where curtains, furniture, clothing, or other flammable objects are less than 42" from the front of the heater.**
- **in high traffic areas.**
- **in windy or drafty areas.**

### ADEQUATE COMBUSTION AND VENTILATION AIR

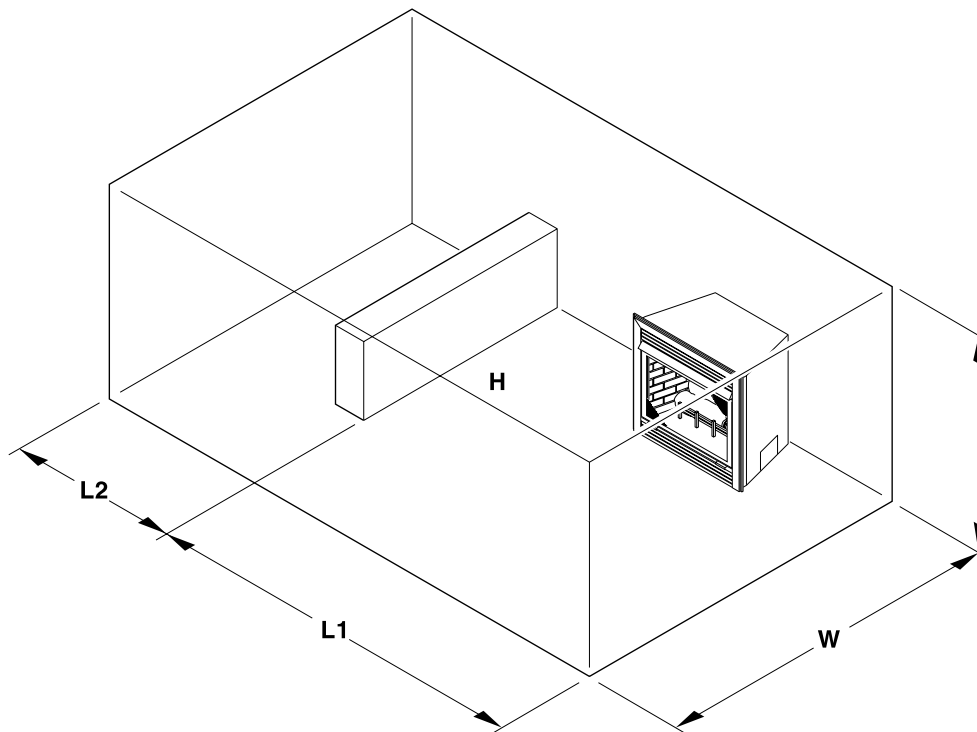
This heater shall not be installed in a confined space or unusually tight construction unless provisions are provided for adequate combustion and ventilation air.

The National Fuel Gas Code defines a confined space as a space whose volume is less than 50 cubic feet per 1,000 BTU per hour (4.8 m<sup>3</sup> per kw) of the aggregate input rating of all appliances installed in that space. An unconfined space is defined as a space whose volume is not less than 50 cubic feet per 1,000 BTU per hour (4.8 m<sup>3</sup> per kw) of the aggregate input rating of all appliances installed in that space. Rooms communicating directly with the space in which the appliances are installed, through openings not furnished with doors, are considered a part of the unconfined space.

### UNUSUALLY TIGHT CONSTRUCTION IS DEFINED AS CONSTRUCTION WHERE...

- a) walls and ceilings exposed to the outside atmosphere have a continuous water vapor retarder with a rating of 1 perm (6 x 10<sup>11</sup> kg per-pa-sec-m<sup>2</sup>) or less with openings gasketed or sealed, and
- b) weather striping has been added on openable windows and doors, and
- c) caulking or sealant are applied to areas such as joints around windows and door frames; between sole plates and doors; between wall-ceiling joints; between wall panels; at penetrations for plumbing, electrical, and gas lines; and at other openings.

## GENERAL INSTALLATION INFORMATION



**Figure 3 - Sample Room for Determining the Maximum Heater Rating**

The following formula can be used to determine the maximum heater rating per the definition of unconfined space:

$$\frac{\text{BTU/HR} = (L1 + L2) \text{ Ft} \times (W) \text{ Ft} \times (H) \text{ Ft} \times 1000}{50}$$

Consider two connecting rooms with an open area between, with the following dimensions:

L1 = 15 1/2 Ft., L2 = 12 Ft., W = 12 Ft., H = 8 Ft.

$$\begin{aligned} \frac{\text{BTU/HR} &= (15 \frac{1}{2} + 12) \times (12) \times (8) \times 1000}{50} \\ &= 52800 \text{ BTU/HR} \end{aligned}$$

If there were a door between the two rooms the calculation would be based only on the room with the heater.

$$\begin{aligned} \frac{\text{BTU/HR} &= (15 \frac{1}{2}) \times (12) \times (8) \times 1000}{50} \\ &= 29760 \text{ BTU/HR} \end{aligned}$$

### WARNING

If the area in which the heater may be operated is smaller than that defined as an unconfined space or if the building is of unusually tight construction, provide adequate combustion and ventilation air by one of the methods described in the National Fuel Gas Code, ANSI Z223.1, 1992, Section 5.3 or applicable local codes.

## INSTALLING OPTIONAL FIREBRICK PANELS

1. Remove optional firebrick panels from packaging. Check to see that you have the following:

- 3 firebrick panels
- two (2) retainer brackets
- two (2) black screws

If any part or parts are missing, contact dealer where you bought fireplace.

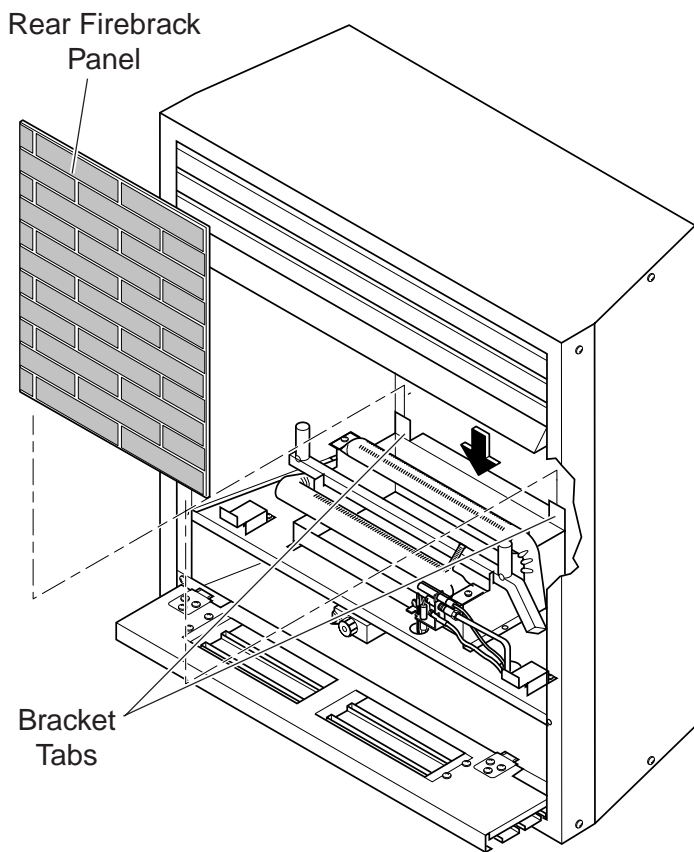
2. Turn off fireplace and allow to cool.

3. Remove fireplace screen (*See Figure 14, page 14*) and logs.

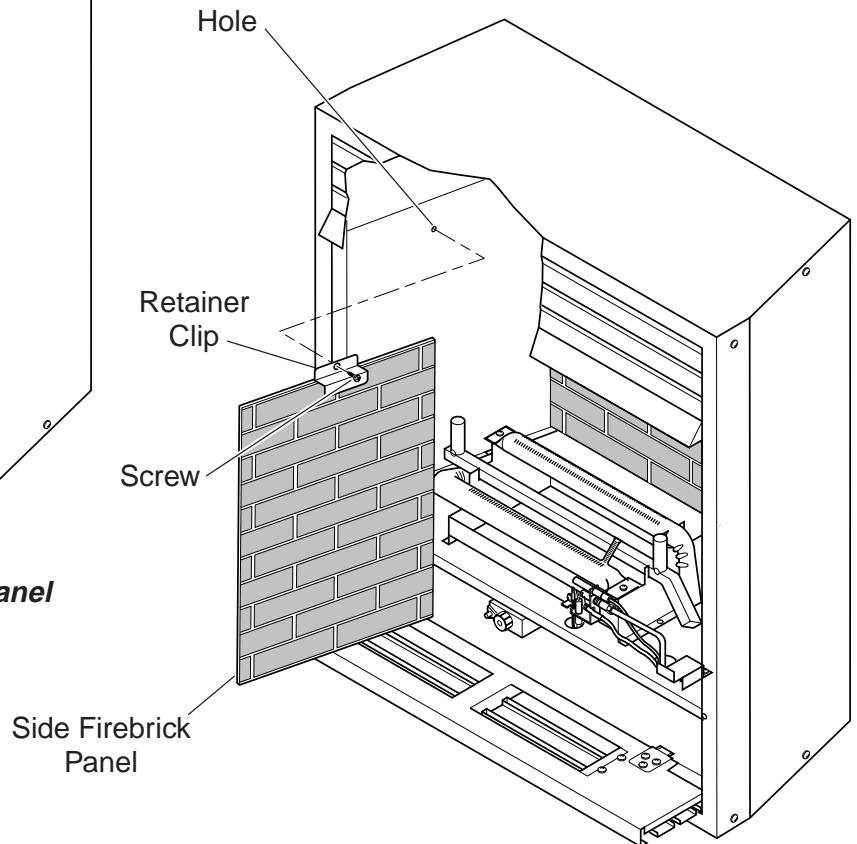
4. Place rear firebrick panel on back wall of firebox. Set bottom of panel behind the bracket tabs of the grate. *See Figure 4.*

5. Place one of the side firebrick panels in cabinet. Line up the hole in the retainer clip with the hole inside the firebox. Using Phillips screwdriver, attach the retainer bracket to inside of firebox. *See Figure 5.*

6. Repeat step five for the other firebrick side panel.



**Figure 4 - Installing Back Firebrick Panel**



**Figure 5 - Installing Side Firebrick Panel**

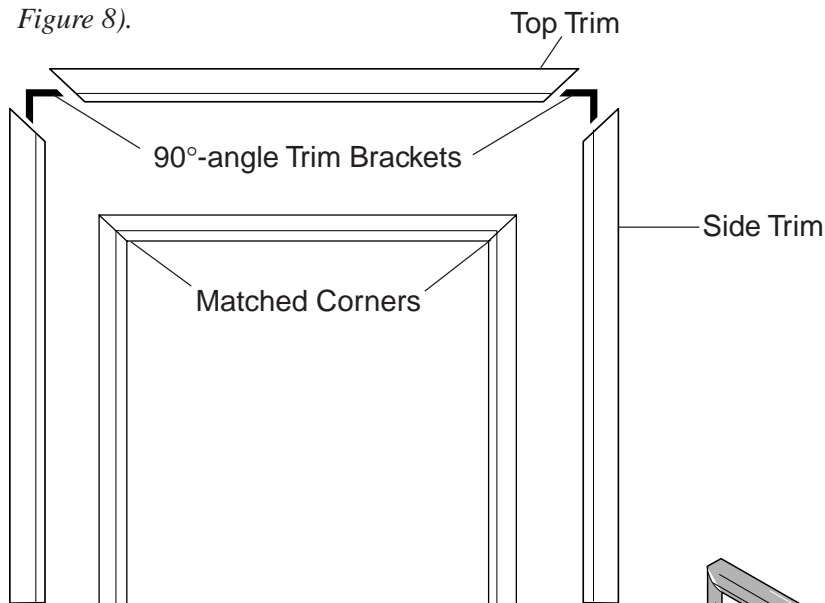
## GENERAL INSTALLATION INFORMATION

### BRASS TRIM INSTALLATION (DFX24/DBX24)

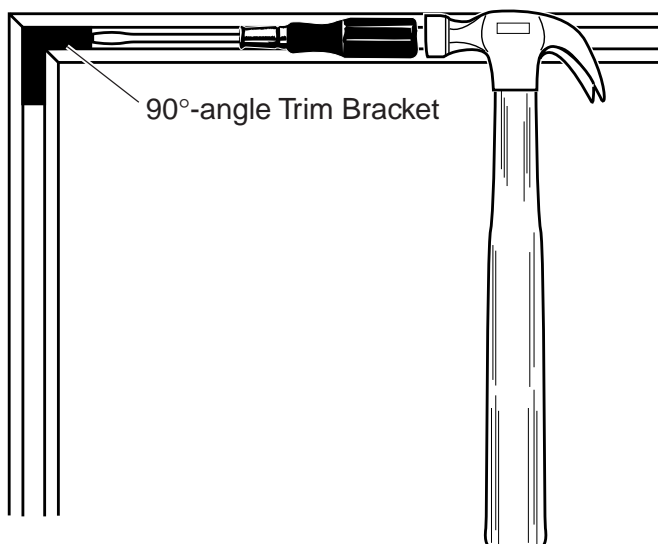
1. Remove brass trim from protective packaging. Remove four (4) brass screws and 2 (two) 90°-angle trim brackets from owner's manual packaging.
2. Lay trim on floor and match corners of side trims to top trim (See Figure 6).
3. Use one 90°-angle trim bracket to join the corner of one piece of side trim to the corner of the top trim piece (See Figure 6). A rubber hammer or handle of a claw hammer will help secure the corners.
4. Repeat for other side.

**NOTE: If you do not attach the trim at the correct corners, use a hammer and screwdriver to tap on the one end of the 90°-angle bracket. This will separate the two pieces of trim (See Figure 8).**

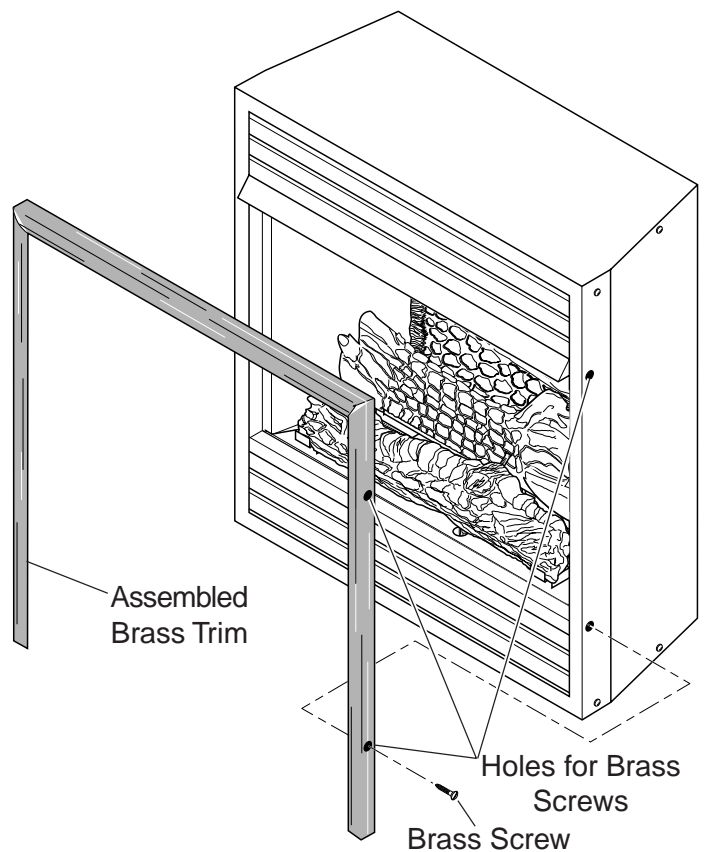
5. Place assembled brass trim on front of heater. Using four (4) brass screws, secure brass trim to sides of heater (See Figure 8).



**Figure 6 - Matching and Joining Corners of Brass Trim with 90°-angle Trim Brackets**

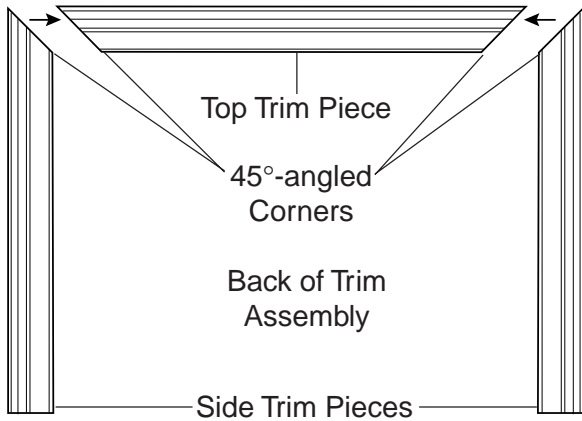


**Figure 7 - Removing the 90°-angled Trim Bracket**

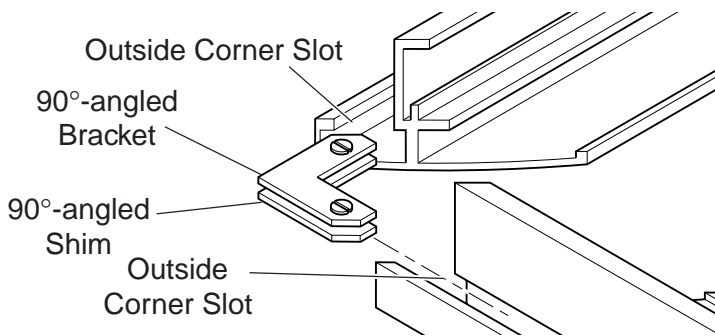


**Figure 8 - Attaching Assembled Brass Trim to Heater**

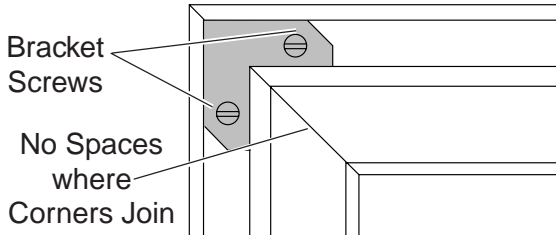
## GENERAL INSTALLATION INFORMATION



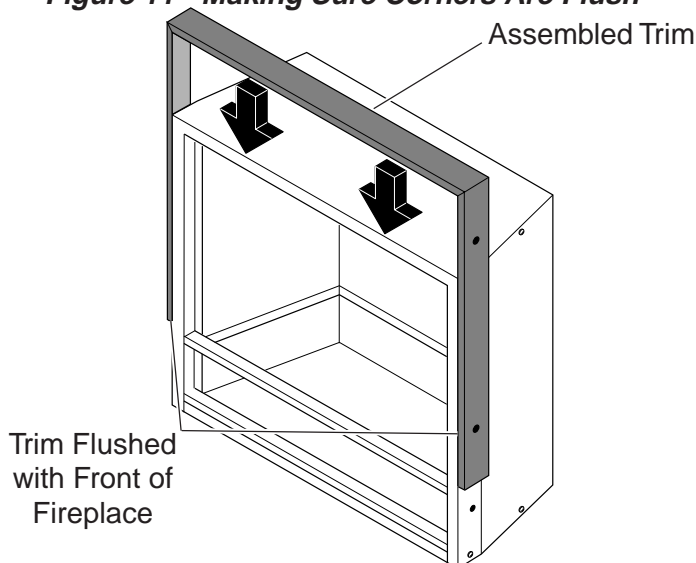
**Figure 9 - Lining Up Corners of Trim Kit**



**Figure 10 - Securing Corners Together**



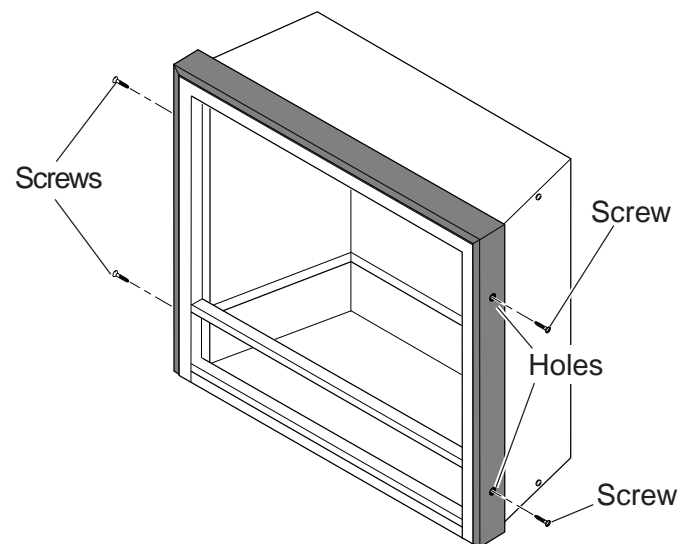
**Figure 11 - Making Sure Corners Are Flush**



**Figure 12 - Sliding Assembled Trim Over the Top of the Heater**

### BRASS TRIM INSTALLATION (DFX32)

1. Remove trim from protective packaging. **Be careful not to scratch the trim.** Remove two (2) 90°-angled mounting brackets and two (2) 90°-angled shims.
2. Lay trim face down on the floor. Line up the 45°-angled corners of the top trim with the 45°-angled corners of the side trims.  
**Note: Both ends of the top piece of trim are mitered. See Figure 9.**
3. Slide one (1) 90°-angled bracket (with attached screws) and one (1) 90°-angled shim in the outside corner slot where the top and side trims meet. *See Figure 10.*
4. Hold the corners together securely. Tighten screws on bracket with flat head screwdriver. Make sure the corners are flush and there are no spaces. **Do not over tighten screws.** Refer to Figure 11.
5. Repeat for other side trim.
6. Slide assembled trim over the top and down the sides of the fireplace. Flush trim with front of fireplace as shown in Figure 12.
7. Align holes in assembled trim with holes in side of fireplace. Using a Phillips screwdriver, attach trim with four (4) screws provided — two for each side of fireplace. Tighten snugly. Refer to Figure 13.



**Figure 13 - Securing Trim to Heater with Four (4) Screws Provided**

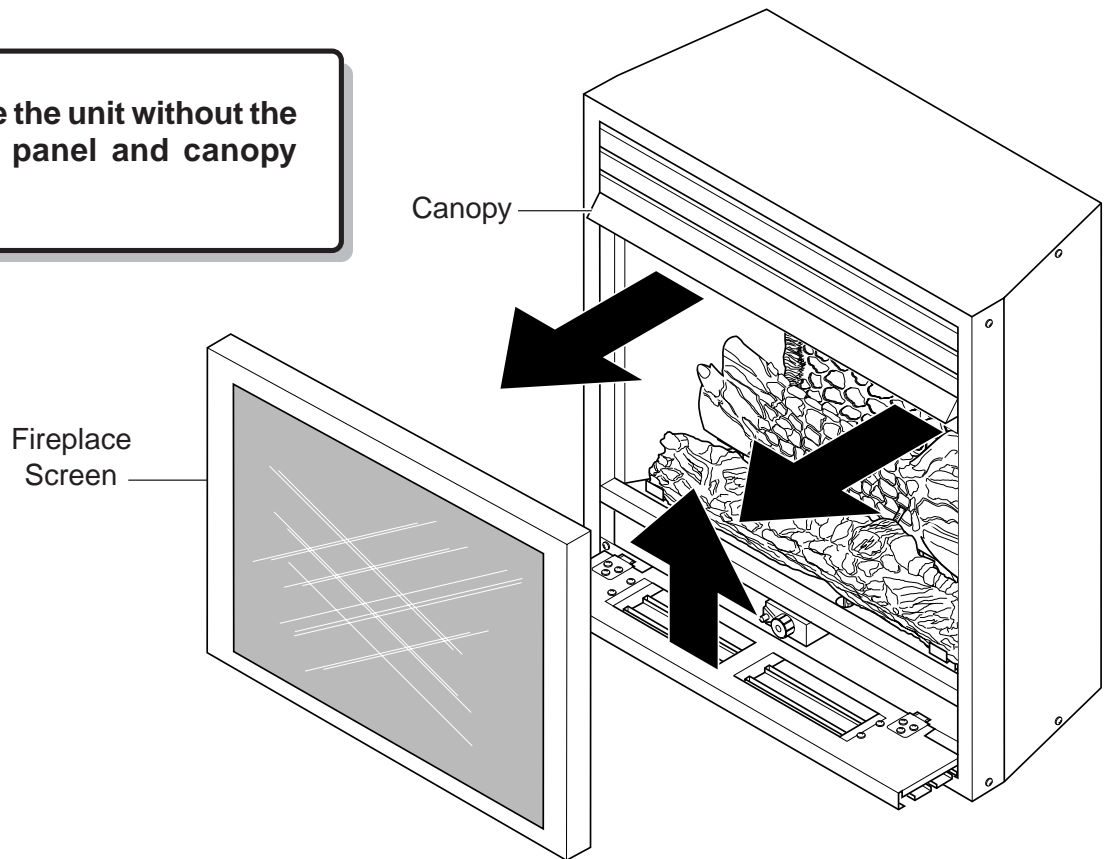
## GENERAL INSTALLATION INFORMATION

### REMOVING SCREEN

Removing fireplace screen frame panel by pushing screen frame panel up and out. Refer Figure 14.

**WARNING**

Do not operate the unit without the screen frame panel and canopy installed.

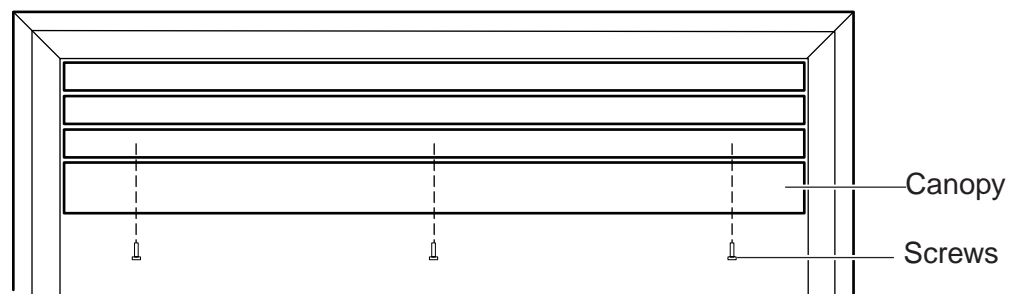


**Figure 14 - Removing Fireplace Screen Frame Panel**

**NOTE:** Fireplace screen must be removed to access log box and to install canopy.

### INSTALLING CANOPY

1. Remove the fireplace screen as described in the previous section.
2. Align the black canopy with the holes in the top frame assembly. Refer to Figure 15.
3. Install the three (3) screws (in owner's manual packaging) which attach the canopy to the top frame assembly. Refer to Figure 15.
4. Tighten all screws. Make sure the canopy is level and secure. Install the fireplace screen.



**Figure 15 - Canopy Installation**

### SECURING HEATER TO FLOOR OR HEARTH

**Note:** Clearance requirements as detailed in “CLEARANCES and HEIGHT REQUIREMENTS” section on page 17 of this manual, must be met before securing the heater in place.

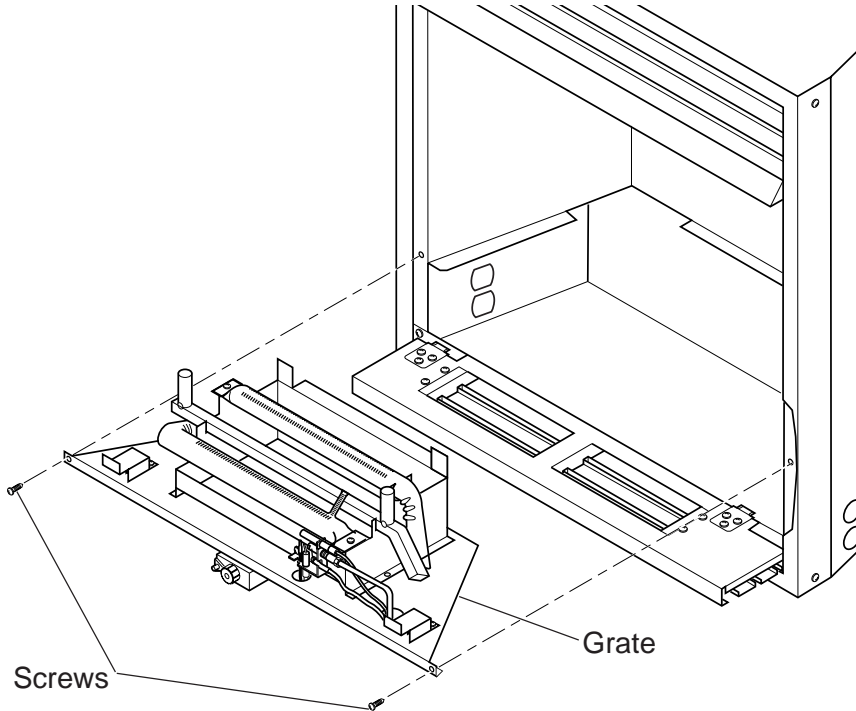
To prevent movement, the heater must be secured to the floor or hearth.

1. Open the control access door and remove the screen.
2. Remove carton containing the four-log set.
3. To remove the grate and base assembly, take out two (2) screws as shown in *Figure 16*.
4. Lift grate and base assembly out of the firebox.

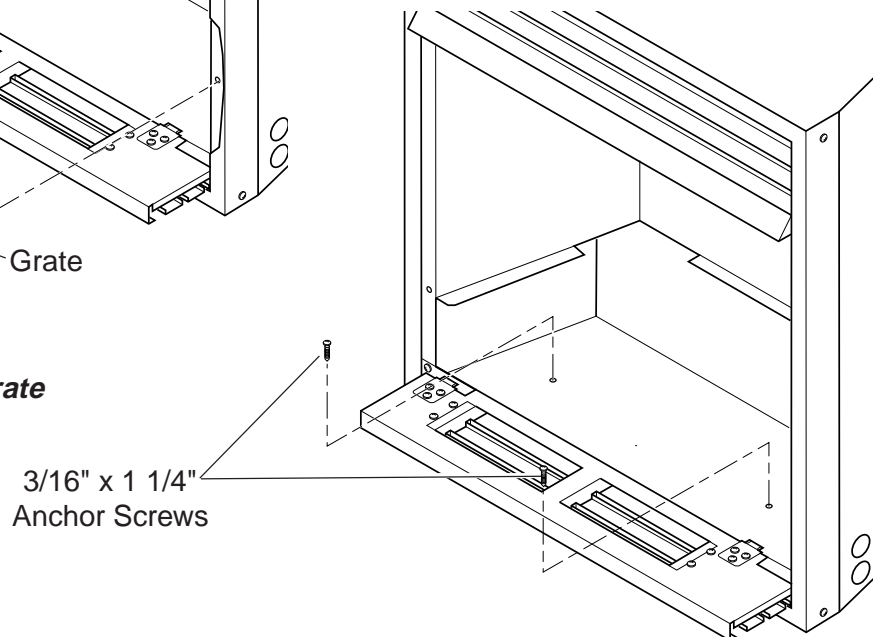
**CAUTION:** Lift grate and base assembly using the grate only.

5. Secure the firebox with two anchoring screws ( $\frac{3}{16}$ " x  $1\frac{1}{4}$ " length) supplied with the fireplace system. Refer to *Figure 17*.

**Note:** If the unit is mounted on carpeting, tile or combustible material without the hearth, a metal or wooden base covering the entire width and depth of the base must be installed.



**Figure 16 - Removing Grate**



**Figure 17 - Securing Heater to Floor or Hearth**



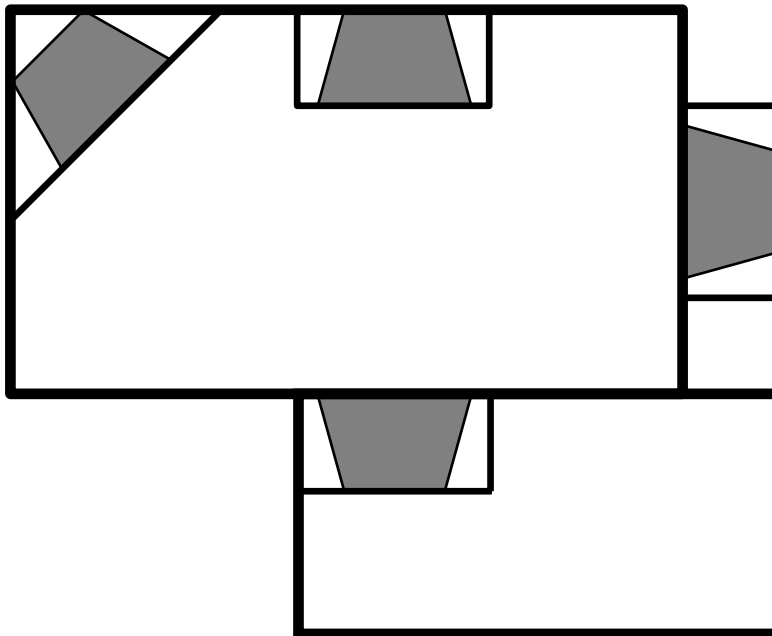
---

## LOCATION OF FIREPLACE

---

Carefully select the best location for installation of your unvented fireplace. The following factors should be taken into consideration.

- Clearance to side wall, ceiling, woodwork and window or other combustibles. Refer to “CLEARANCES and HEIGHT REQUIREMENTS” section on page 17. Minimum clearances to combustibles **must be maintained**.
- Location must not be affected by drafts caused by kitchen exhaust fans, ceiling fans, return air registers for forced air furnaces / air conditioners, windows or doors.
- Installation must provide adequate ventilation and combustion air.
- **DO NOT INSTALL THE DFX MODEL IN A BEDROOM OR BATHROOM. THE DBX MODEL MAY BE INSTALLED IN A BEDROOM, BUT NOT IN A BATHROOM.**
- Location should be out of high traffic areas and away from furniture and draperies due to heat from firebox.
- Never obstruct the front opening of the unvented fireplace or restrict the flow of combustion and ventilation air.
- Minimize modifications to existing construction. *Refer to Figure 18* below for location suggestions.
- Do not install in the vicinity where gasoline or other flammable liquids may be stored. The unvented firebox must be kept clear and free from the combustible materials.



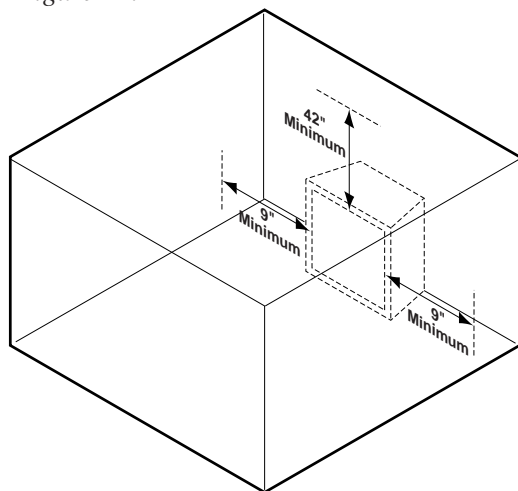
*Figure 18 - Suggested Locations*

## CLEARANCES and HEIGHT REQUIREMENTS

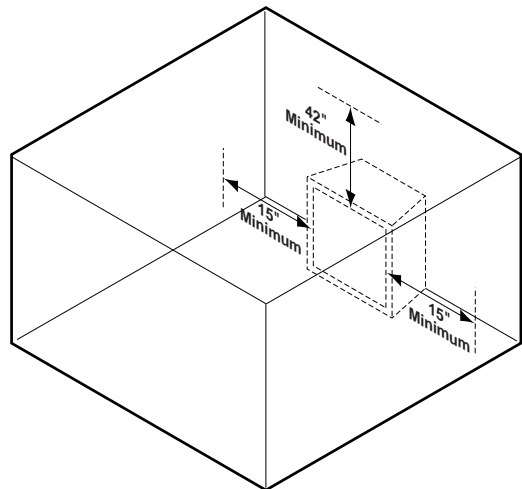
Ensure that minimum clearances shown in *Figures 14 and 15* are maintained. Left and right clearances are determined when facing the front of the firebox.

Follow these instructions carefully to ensure safe installation. Failure to follow these requirements may create a fire hazard.

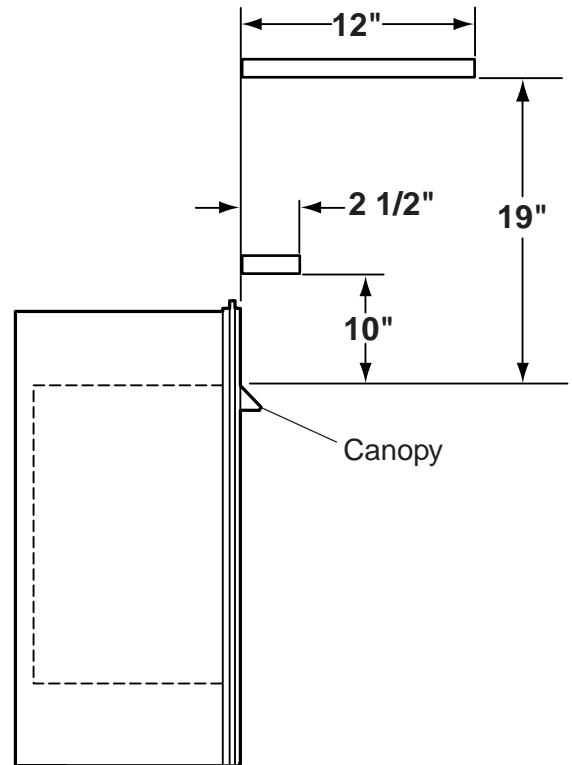
1. **Sidewall Clearances** — The clearance from the inside of the appliance to any combustible adjacent wall should not be less than 9" for the DBX24/DFX24 or less than 15" for the DFX32. Refer to *Figures 19 and 20*.
2. **Ceiling Clearance** — The ceiling must be at least 42" from the top of the firebox opening. Refer to *Figures 19 and 20*.
3. **BackWall Clearance** — The appliance may be placed against a combustible back wall.
4. **Floor Clearance** — The fireplace may not be installed onto any combustible flooring material, such as carpeting, vinyl or tile without the hearth or a min. 22 Ga (0.030") metal or a minimum 1/2" wooden base covering the entire width and depth of the base.
5. **Mantel clearances** — The canopy supplied with the unit must be installed. If a combustible mantel is installed. It must meet the clearance requirements detailed in *Figure 21*.



**Figure 19 - Clearances and Height Requirements for DFX24/DBX24**



**Figure 20 - Clearances and Height Requirements for DFX32**



**Figure 21 - Minimum Mantel Clearances**

### WARNING

The dimensions shown in Figures 19 through 21 are minimum clearances to maintain in installing this heater. Left and right clearances are determined when facing the front of the heater.

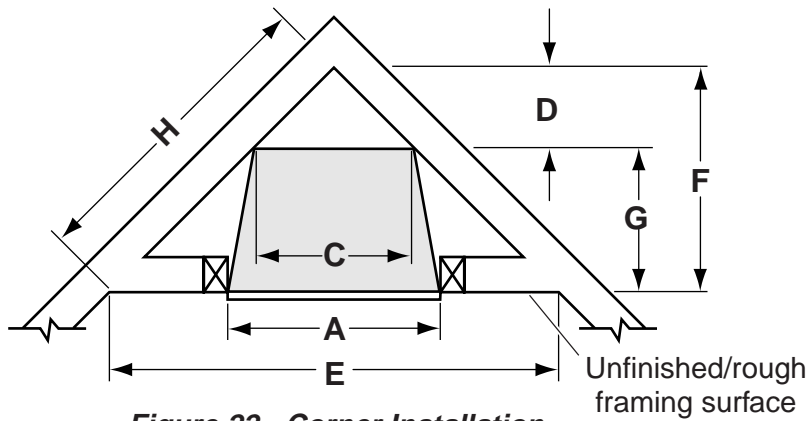
Follow these instructions carefully to ensure safe installation. Failure to follow instructions exactly can create a fire hazard.

# FIREPLACE FRAMING

If unit is to be “built in”, fireplace framing can be built before or after the appliance is set in place. **BE SURE THAT ALL PACKING MATERIAL HAS BEEN REMOVED FROM THE UNDERSIDE OF THE UNIT PRIOR TO SETTING THE FIREBOX IN PLACE.** Construct fireplace framing following *Figures 22 through 25*. Refer to *Figure 2* on page 8 for fireplace dimensions. The framing headers may rest directly on top of the firebox.

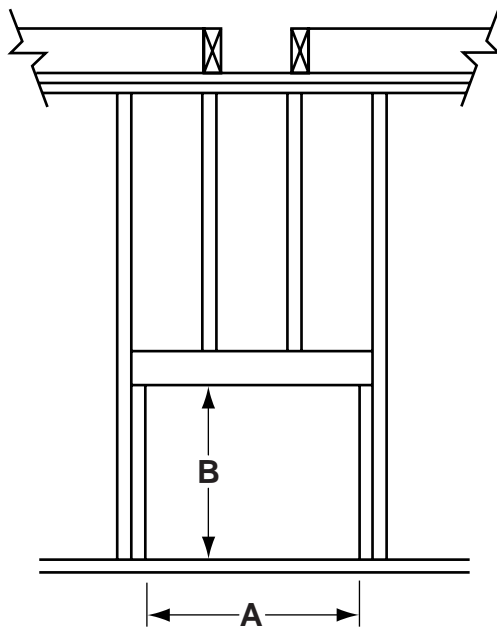
The fireplace may be installed directly on a combustible floor or a raised platform of an appropriate height. Do not place fireplace on carpeting, vinyl, tile or other soft floor coverings. It may, however, be placed on flat wood, plywood, particle board or other hard surfaces. Be sure fireplace rests on a solid continuous floor or platform with appropriate framing for support and so that no cold air can enter from under the firebox.

Anchor fireplace to the side framing members using nailing flanges.

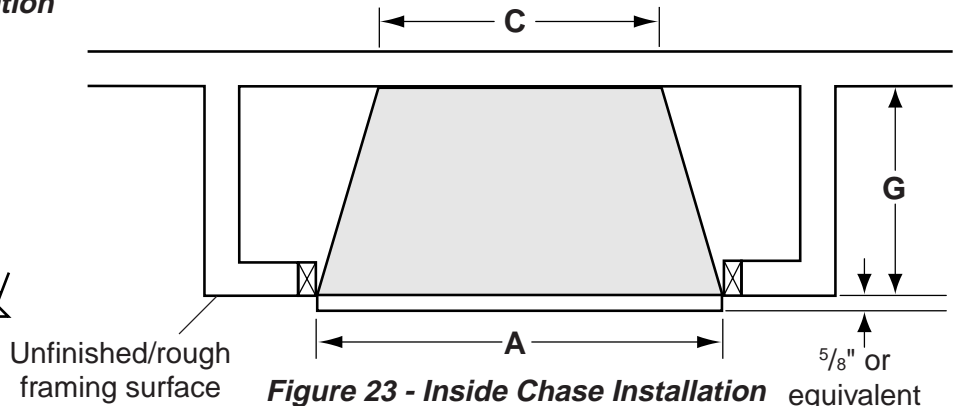


**Figure 22 - Corner Installation**

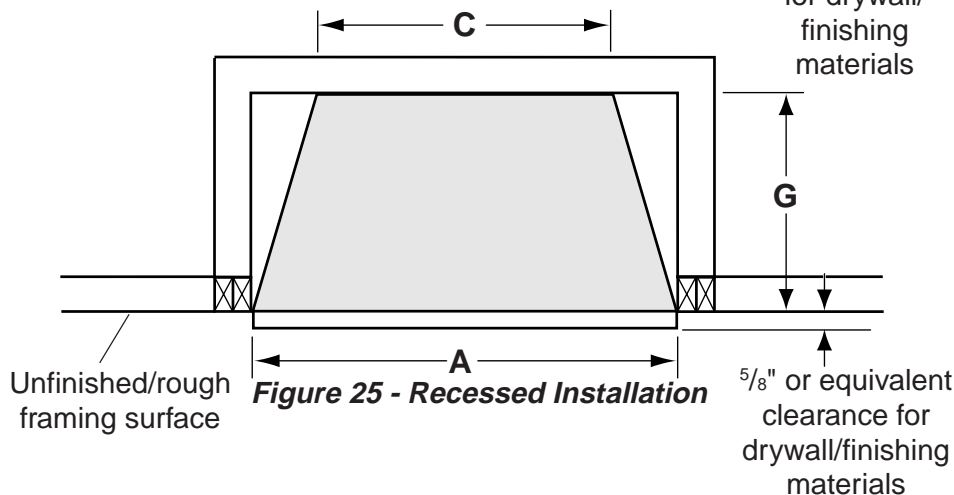
	DFX24	DBX24	DFX32
A	24 <sup>3</sup> / <sub>4</sub>	24 <sup>3</sup> / <sub>4</sub>	32 <sup>1</sup> / <sub>2</sub>
B	26 <sup>3</sup> / <sub>4</sub>	26 <sup>3</sup> / <sub>4</sub>	30 <sup>1</sup> / <sub>4</sub>
C	21 <sup>1</sup> / <sub>2</sub>	21 <sup>1</sup> / <sub>2</sub>	29 <sup>1</sup> / <sub>4</sub>
D	11 <sup>1</sup> / <sub>8</sub>	11 <sup>1</sup> / <sub>8</sub>	14 <sup>1</sup> / <sub>2</sub>
E	42 <sup>1</sup> / <sub>2</sub>	42 <sup>1</sup> / <sub>2</sub>	53 <sup>3</sup> / <sub>4</sub>
F	21	21	26 <sup>3</sup> / <sub>4</sub>
G	10 <sup>1</sup> / <sub>2</sub>	10 <sup>1</sup> / <sub>2</sub>	12 <sup>1</sup> / <sub>4</sub>
H	29 <sup>7</sup> / <sub>8</sub>	29 <sup>7</sup> / <sub>8</sub>	37 <sup>7</sup> / <sub>8</sub>



**Figure 24 - Stud Location**



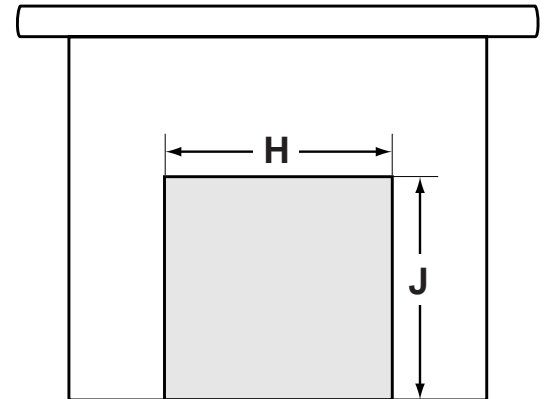
**Figure 23 - Inside Chase Installation**



**Figure 25 - Recessed Installation**

When finishing a custom cabinet, mantel, or other built-in enclosure, the opening size to accommodate the fireplace with trim installed is as follows:

	DFX24 w/ trim	DBX24 w/ trim	DFX32 w/trim
H	24 <sup>3/4</sup>	24 <sup>3/4</sup>	32 <sup>13/16</sup>
J	26 <sup>3/4</sup>	26 <sup>3/4</sup>	31 <sup>1/4</sup>

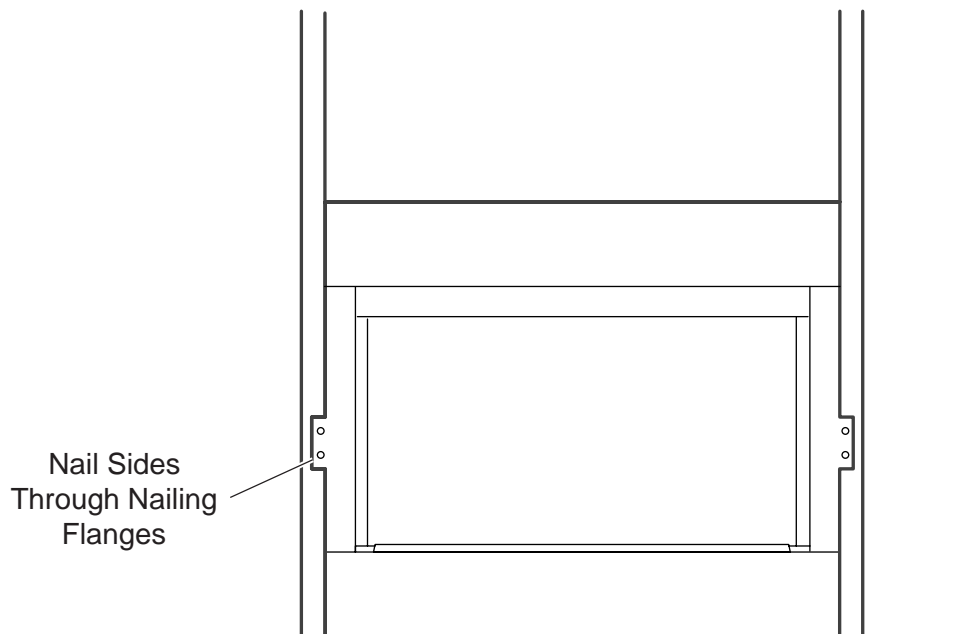


**Figure 26 - Custom Cabinet**

**WARNING**

The fireplace must be installed giving full consideration to the clearance and height requirements identified in this manual.

1. Bend out the nailing flanges located on each side of the firebox.
2. Slide the firebox into prepared framing or position firebox in its final position and frame later.
3. Level the firebox by checking the top edge of the firebox. Shim if necessary.
4. Anchor firebox to the side framing members using 8d nails or other suitable fasteners. *Refer to Figure 27.*
5. The canopy must be installed for safe operation of the heater. Refer to page 14 for canopy installation details.



**Figure 27 - Location of Nailing Flanges**

## CONNECTING THE GAS

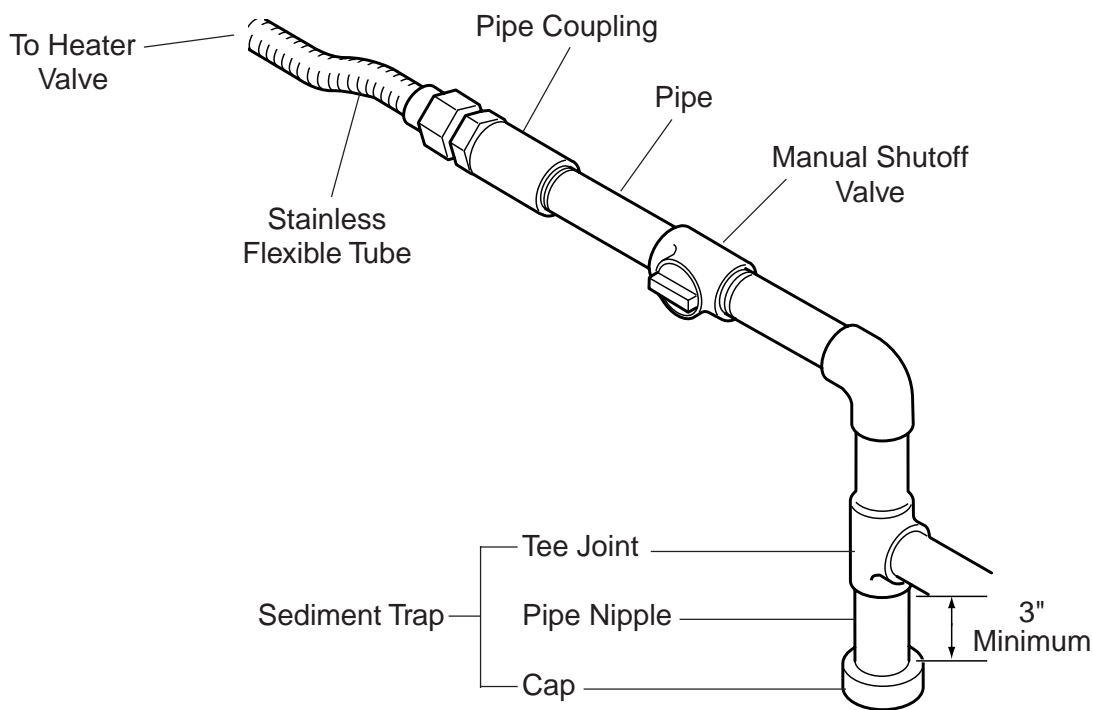
**NOTICE:** A qualified gas appliance installer must connect the heater to the gas supply. Consult all local codes.

### CAUTION

Use new black iron pipe, steel pipe, copper tubing or internally tinned copper tubing. Internally tinned copper tubing can only be used per National Fuel Code, section 2.6.3, providing gas meets sulfide limits, and where permitted by local codes. Gas piping system must be sized to provide minimum inlet pressure (listed on Data Plate) at the maximum flow rate (BTU/Hr). Undue pressure loss will occur if the pipe is too small.

A manual shutoff valve must be installed upstream of the appliance. Union tee and plugged 1/8" NPT pressure tapping point should be installed upstream of the appliance. Refer to Figure 28.

A sediment trap should be installed upstream to prevent moisture and contaminants from passing through the pipe to appliance controls and burners. Failure to do so could prevent the appliance from operating reliably. Refer to Figure 28.



**Figure 28 - Gas Connection**

**IMPORTANT:** Loosen the pipe adapter on the flex tube before installing to the system piping.

**CHECK GAS TYPE:** The gas supply must be the same as stated on the heater's rating plate. If the gas supply is different, **DO NOT INSTALL THE HEATER.** Contact your dealer for the correct model.

Always use an external regulator for all propane/LPG heaters only, to reduce the supply tank pressure to a maximum of 13" w.c. This is in addition to the internal regulator in the heater valve.

### WARNING

**Connecting directly to an unregulated propane/LPG tank can cause an explosion.**

Test all gas joints from the gas meter to the heater valve for leaks using a gas analyzer or soap and water solution after completing connection. **DO NOT USE AN OPEN FLAME.**

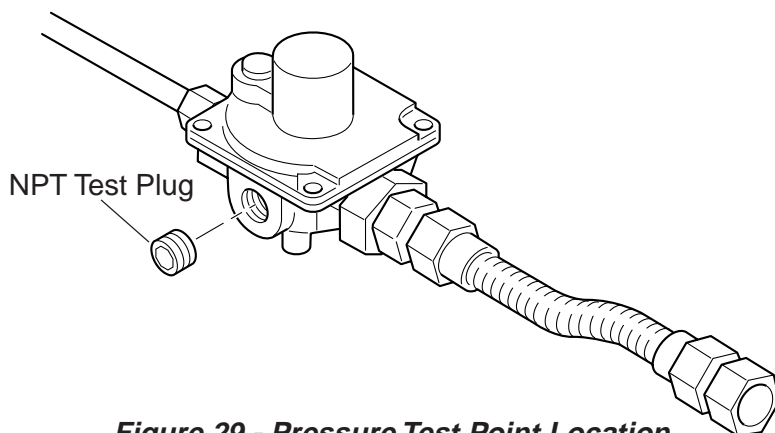
Check the gas pressure with the appliance burning and the control set to **HIGH**.

Open control access door at bottom front of unit to find valve and regulator referred to below.

### MANUAL CONTROL (Figure 29)

The pressure regulator is preset and locked to discourage tampering. If the pressure is not as specified, replace the regulator with the correct part from the parts list in this manual.

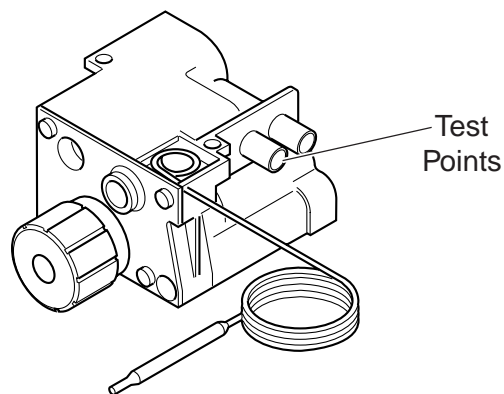
Remove 1/8" NPT plug, located on side of regulator body. Install fitting and tubing to pressure gauge. After taking pressure reading, reinstall test plug. Check for gas leaks.



**Figure 29 - Pressure Test Point Location**

### THERMOSTAT CONTROL (Figure 30)

Turn captured screw counter clockwise two or three turns and then place tubing to pressure gauge over test point (Use test point closest to control knob). After taking pressure reading, be sure and turn captured screw clockwise firmly to reseal. Do not over torque. Check for gas leaks.

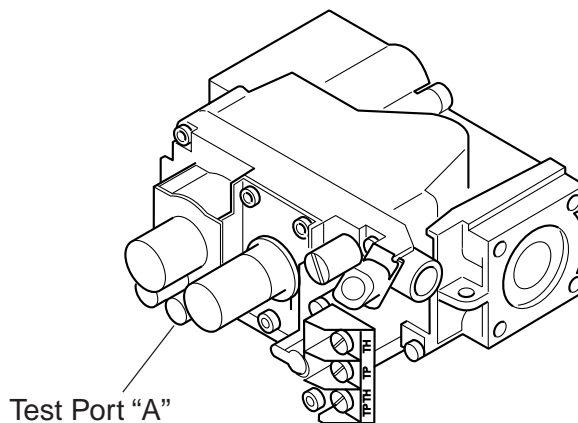


**Figure 30 - Alternate Test Point Location for Thermostat Control Unit**

### MILLIVOLT CONTROL (Figure 31)

The valve regulator controls the burner pressure which should be checked at the pressure test point.

Turn captured screw counter clockwise two or three turns and then place tubing to pressure gauge over test point. (Use test point "A" closest to gas inlet). After taking pressure reading, be sure and turn captured screw clockwise firmly to reseal. Do not over torque. Check for gas leaks.



**Figure 31 - Pressure Test Point Location**

## ELECTRICAL WIRING (MILLI-VOLT)

The milli-volt valve is a self-powered combination gas control **THAT DOES NOT REQUIRE 110 VAC TO OPERATE.**

### CAUTION

Label all wires prior to disconnection when servicing controls. Wiring errors can cause improper and dangerous operation. Verify proper operation after servicing.

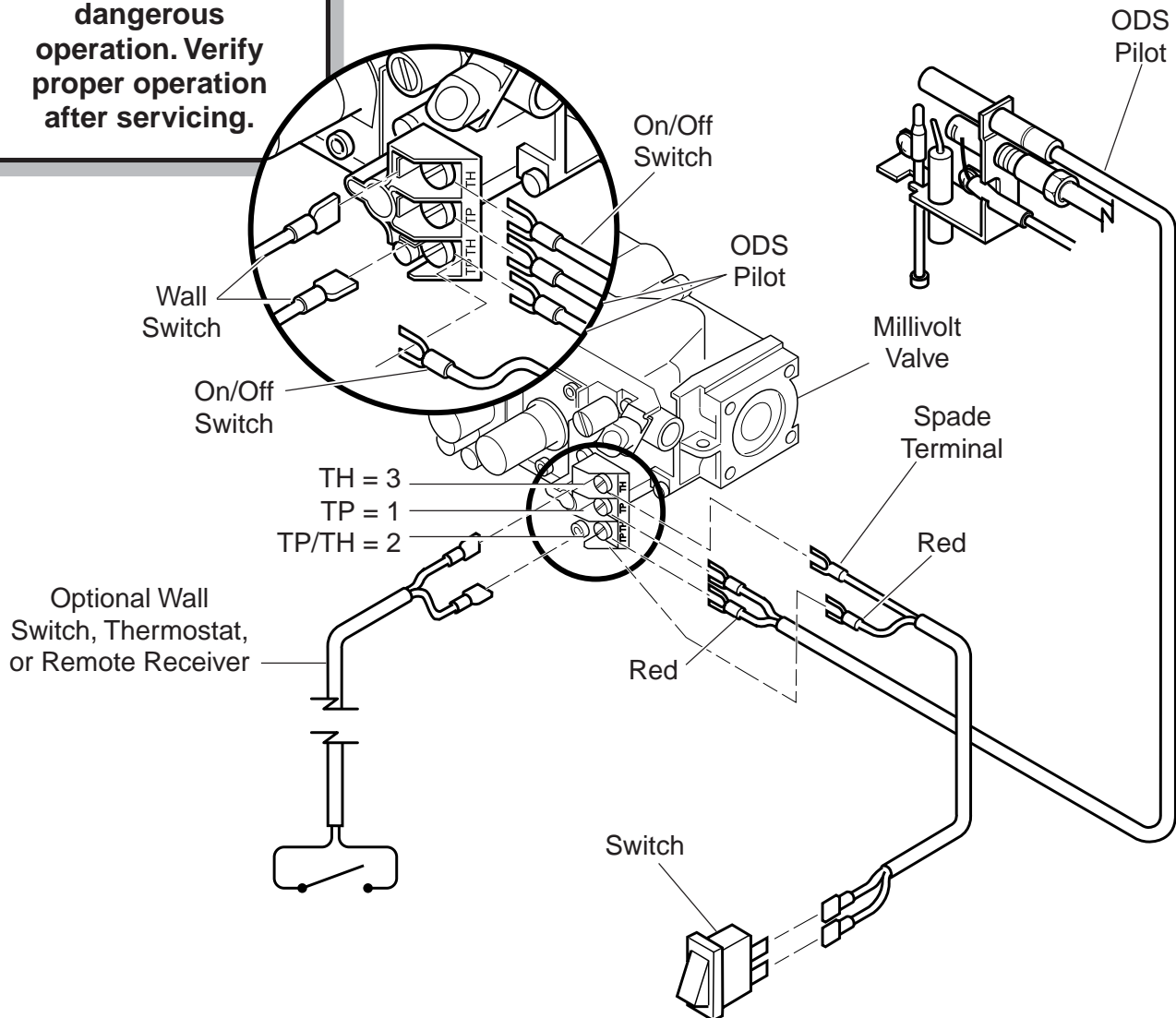


Figure 32 - Wiring Diagram

### CONNECTING OPTIONAL WALL SWITCH OR THERMOSTAT

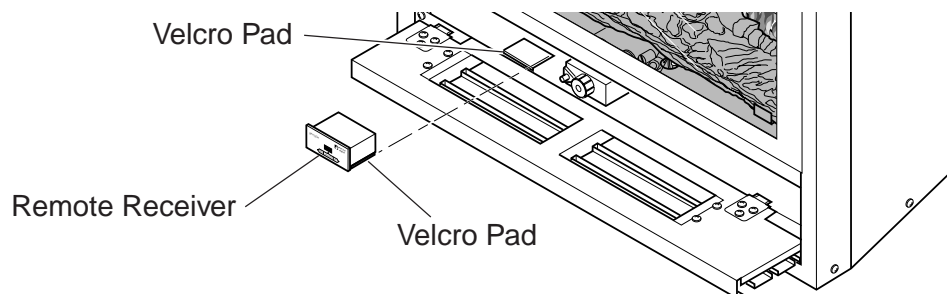
1. Use 18 awg, two-wire cable, 20 feet maximum length.
2. At one end of the cable, connect both wires to the wall switch or thermostat. At the other end, connect one wire to TP/TH and one wire to TH. The color of the wires does not matter.



## CONNECTING REMOTE RECEIVER

**THESE INSTRUCTIONS SUPERCEDE THE SECTION ENTITLED “HEARTH MOUNT” IN THE MILLI-VOLT HAND-HELD REMOTE INSTRUCTIONS SUPPLIED WITH THE REMOTE.**

1. Cut cable to length (approximately 12") for placement in the fireplace.
2. Strip back 1/4" of the insulation from both ends of each wire.
3. Connect two connectors to the wires at one end of the cable.
4. Insert the opposite ends of the wires into the receiver wire terminals and tighten the screws.
5. Connect the connectors to the terminals labeled TH/TP and TH on the millivolt valve. (See Figure 32, page 20). Do not let wire touch grate or front burner.
6. Stick velcro pads with self-adhesive backing to bottom of remote receiver and to floor of compartment behind access panel.
7. Attach remote receiver to firebox with velcro pads. Control switch must face forward.



**Figure 33 - Installing Remote Receiver**

## CHECKING SYSTEM OPERATION

The millivolt system and individual components may be checked with a millivolt meter having a 0-1000 mV range. Conduct each check shown in chart below by connection meter test leads to terminals as indicated.

CHECK TEST	TO TEST	CONNECT METER LEADS TO TERMINALS	THERMOSTAT CONTACTS	METER READING SHOULD BE
A	COMPLETE SYSTEM	2 & 3	CLOSED	CLOSED
B	THERMOPILE OUTPUT	1 & 2	OPEN	OPEN

### A. COMPLETE MILLIVOLT SYSTEM CHECK

**(“A” Reading - Thermostat contacts CLOSED - Control Knob “ON” - Main burner should be come ON)**

- a. If the reading is more than 100 millivolts and the automatic valve still does not come on, replace the control.
- b. If the closed circuit reading (“A” reading) is less than 100 milli-volts, determine cause for low reading, proceed to Section B below.

### B. Thermopile Output Reading Check

**(“B” Reading - Thermostat contacts OPEN - Main burner OFF)**

1. Check gas pressure to the unit. If gas pressure is within minimum and maximum on data plate, then check pilot voltage, 325 millivolts minimum. If the minimum milli-volt reading is not obtainable, replace pilot.

## LOG PLACEMENT

**Before you begin** — This unit is supplied with a set of three ceramic fiber logs. Do not handle these logs with your bare hands. Always wear gloves to prevent skin irritation from ceramic fibers. After handling logs, wash your hands gently with soap and water to remove any traces of fibers.

### WARNING

The positioning of the logs is critical to the safe and clean operation of this heater. Sooting and other problems may result if the logs are not properly and firmly positioned in the appliance. Never add additional logs or embellishments such as pine cones, vermiculite or rock wool to the heater.

### WARNING

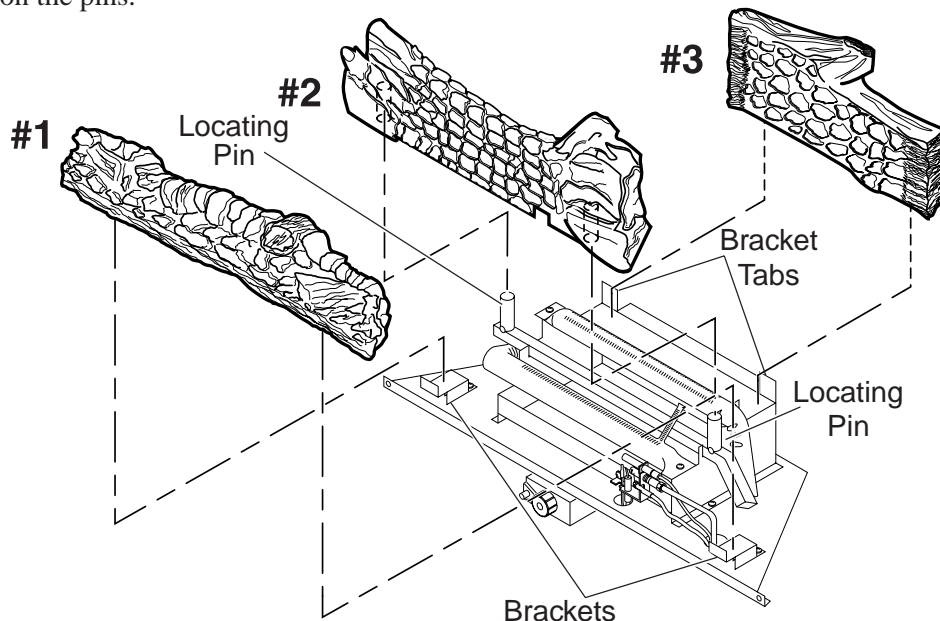
Failure to position the parts in accordance with these diagrams or failure to use only parts specifically approved with this heater may result in property damage or personal injury.

### CAUTION

**DO NOT** sprinkle volcanic rock on the logs or around the pilot or the main burner. This may cause sooting. Only place volcanic rock on the floor of the fireplace. During initial operation of the new heater, burning logs will give off a paper burning smell and orange flames will be present. Simply open the windows for a few hours to vent the odor.

### PROPER INSTALLATION SEQUENCE (DFX24)

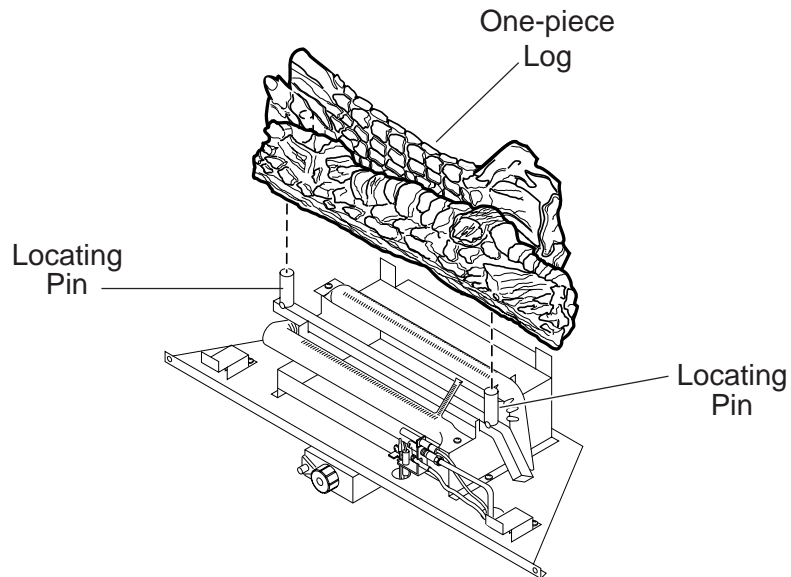
1. Install the **rear log (#3)** in log bracket. Visually check to verify the log is securely placed.
2. Install the **front log (#1)** in bracket. Visually center log.
3. Install the **center log (#2)** behind the front log on the remaining set of locating pins. Visually check to verify the log is securely placed on the pins.



*Figure 34 - Proper Sequence of Log Installation (DFX24)*

**PROPER INSTALLATION SEQUENCE (DBX24)**

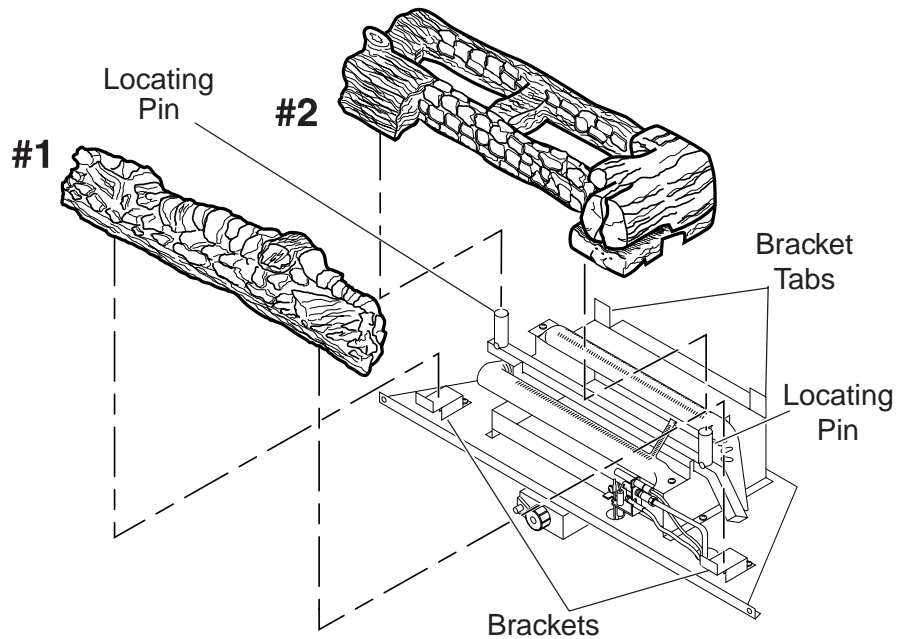
Install one-piece log on two locating pins.



*Figure 35 - Proper Sequence of Log Installation (DBX24)*

**PROPER INSTALLATION SEQUENCE (DFX32)**

1. Position the **rear log (#2)** in logbracket and on locating pins.
2. Install the **front log (#1)** in bracket. Visually center log.



*Figure 36 - Proper Sequence of Log Installation (DFX32)*

---

## FLAME APPEARANCE

---

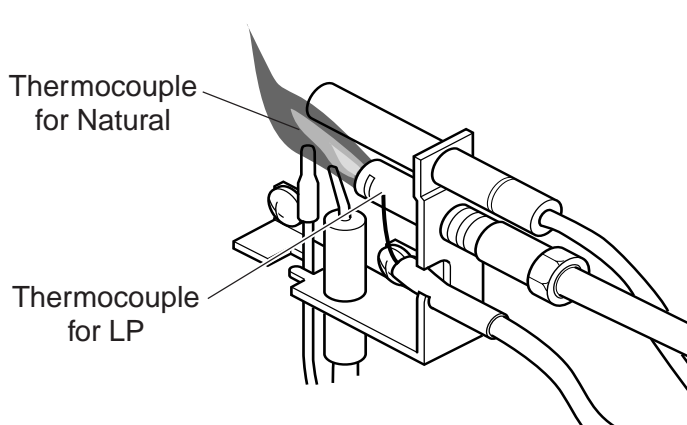
Flames from the pilot, front and rear burner should be visually checked as soon as the heater is installed. In addition, periodically check the flames visually during operation.

### CHECKING THE PILOT FLAME

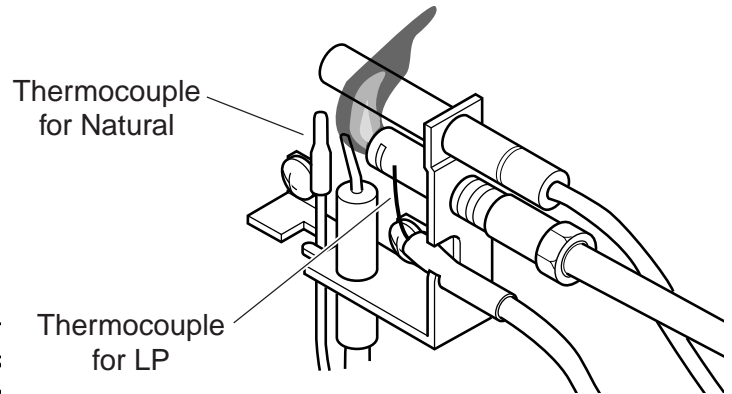
The pilot flame must always be present when the heater is in operation. It should just touch the top of the thermocouple tip for natural. Refer to Figure 37 and 39 for correct pilot flame.

If the pilot flame does not touch the thermocouple, then the main burner cannot function reliably. Refer to Figure 38 and 40 for incorrect shape of pilot flame.

### MILLI-VOLT CONTROL

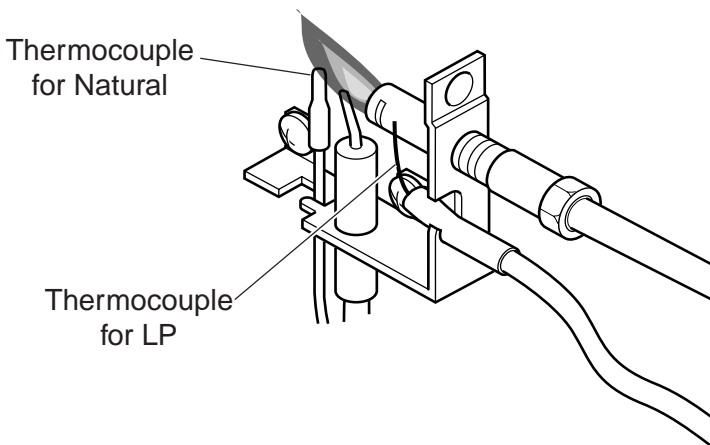


**Figure 37 - Correct Appearance of Pilot Flame**

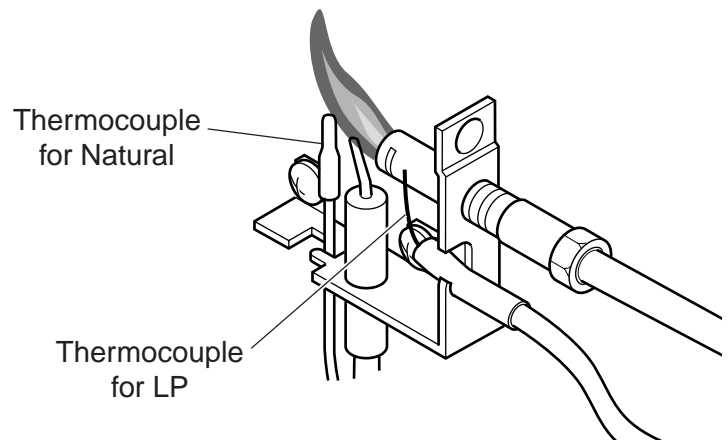


**Figure 38 - Incorrect Appearance of Pilot Flame**

### MANUAL AND THERMOSTAT CONTROL



**Figure 39 - Correct Appearance of Pilot Flame**



**Figure 40 - Incorrect Appearance of Pilot Flame**

## CHECKING THE BURNER FLAME

In normal operation at full rate after 15 minutes, the following flame appearances should be observed:

### DFX24 MODEL

The rear flames above and behind log #2, and in front of log #3, may be yellow. The flames should extend approximately 2" - 4" above log #2. Refer to Figure 41.

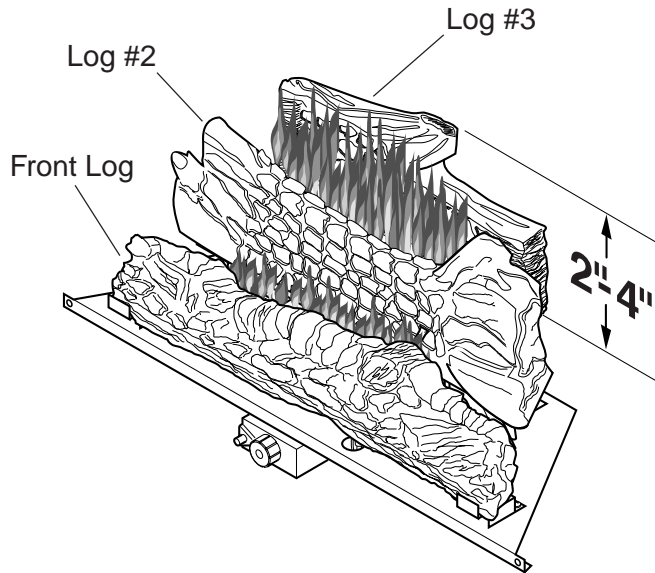


Figure 41 - Correct Appearance of Rear Flames (DFX24 Model)

### DFX32 MODEL

The rear flames above and inside log #2 may be yellow. The flames should extend approximately 2" - 4" above log #2. Refer to Figure 42.

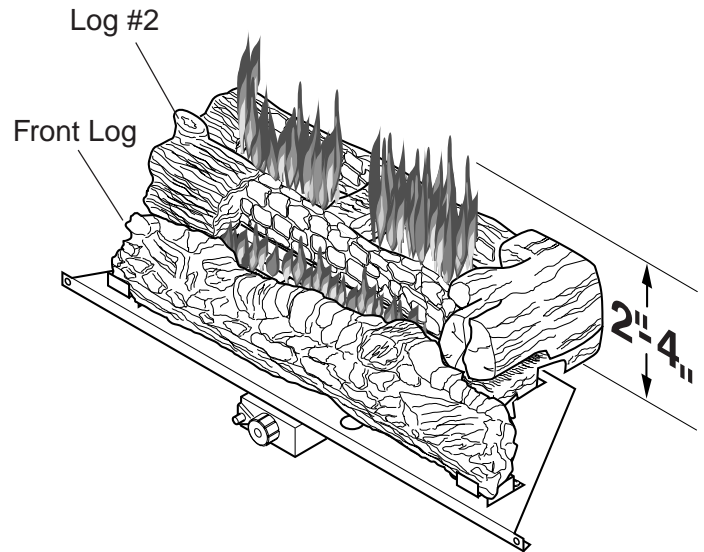


Figure 42 - Correct Appearance of Rear Flames (DFX32 Model)

### DBX24 MODEL

The flames inside the one-piece log may be yellow. The flames should extend approximately 2" - 4" above the log. Refer to Figure 43.

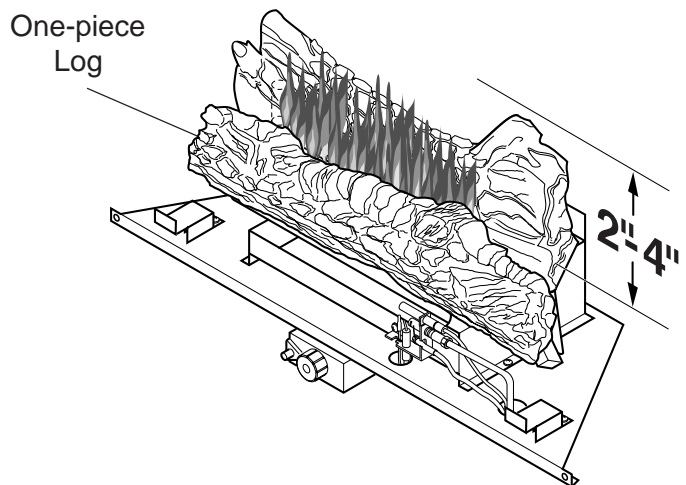


Figure 43 - Correct Appearance of Rear Flames (DBX24 Model)

The front burner flames are **blue**, becoming yellowish as they hit the bumps on the face of the front log. The face of the front log will glow a bright reddish orange when the heater is in operation.

**NOTE:** When the log set is turned on for the very first time, the burner flames in front of log #2 will appear an opaque orange on the surface of log #2. After two or three hours of continuous operation on the highest setting, the normal bright orange/red glow should be visible.

---

## CHECKING THE BURNER FLAME

---

### OPERATING INSTRUCTIONS

**Avoid any drafts that alter burner flame patterns.** Do not allow fans to blow directly into the fireplace. Do not place a blower inside the burn area of the firebox. Ceiling fans may create drafts that alter flame patterns. Sooting and improper burning will result.

During manufacturing, fabricating and shipping, various components of this appliance are treated with certain oils, films or bonding agents. These chemicals are not harmful, but may produce annoying smoke and smells as they are burned off during the initial operation of the appliance, possibly causing headaches or eye or lung irritation. *This is a normal and temporary occurrence.*

The initial break-in operation should last two to three hours with the burner at the highest setting. Provide maximum ventilation by opening windows or doors to allow odors to dissipate. Any odors remaining after this initial break-in will be slight and will disappear with continued use.

This appliance must not be used with glass doors in the closed position. This can lead to pilot outages and severe sooting outside the fireplace.

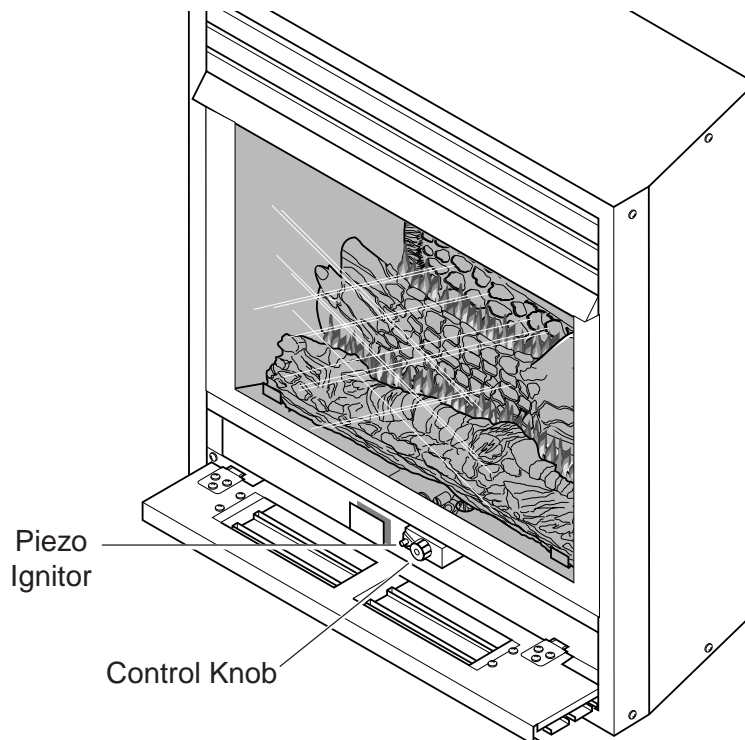
**FOR YOUR SAFETY READ BEFORE LIGHTING****WARNING**

If you do not follow these instructions exactly, a fire or explosion may result causing property damage, personal injury or loss of life.

- A.** This appliance is equipped with an ignition device which automatically lights the pilot. Do not try to light the pilot by hand.
- B.** BEFORE OPERATING smell all around the appliance area for gas. Be sure to smell next to the floor because some gas is heavier than air and will settle on the floor.

**WHAT TO DO IF YOU SMELL GAS:**

- Do not attempt to light any appliance.
  - Do not touch any electric switch; do not use any phone in your building.
  - Immediately call your gas supplier from a neighbor's phone. Follow the gas supplier's instructions.
  - If you cannot reach your gas supplier, call the fire department.
- C.** Use only your hand to push in, or turn the gas control knob. Never use tools. If the knob will not push in or turn by hand, don't try to repair it. Call a qualified service technician. Force or attempted repair may result in a fire or explosion.
- D.** Do not use this appliance if any part of it has been under water. Immediately call a qualified service technician to inspect the appliance and to replace any part of the control system and any gas control that has been under water.



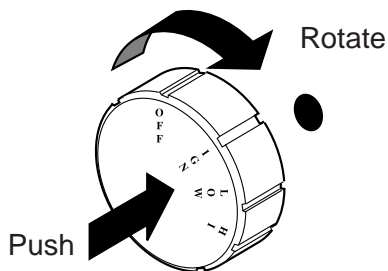
**Figure 44 - Location of Piezo Ignitor & Control Knob**



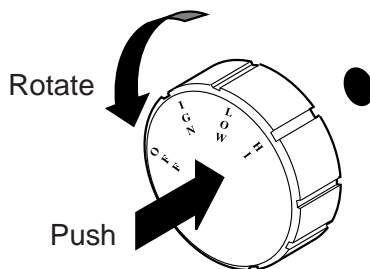
# OPERATING INSTRUCTIONS

## MANUAL CONTROL LIGHTING INSTRUCTIONS

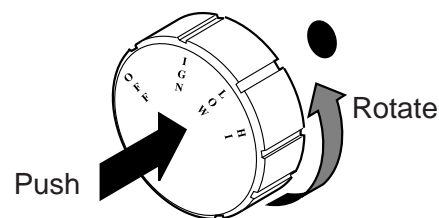
1. STOP! Read the safety information.
2. Make sure the manual shutoff valve is fully open.
3. This heater is equipped with an ignition device (piezo) which automatically lights the pilot.
4. Refer to *Figure 44, page 29* for the location of the piezo ignitor and control knob. Push in gas control knob slightly and turn control knob clockwise to the OFF position.  
**NOTE:** Knob cannot be turned to OFF unless knob is pushed in slightly. Do not force.
5. Wait 5 minutes to clear out any gas. Then smell for gas, including near the floor. If you smell gas STOP! Follow the instructions under “WHAT TO DO IF YOU SMELL GAS”, page 29. If you do not smell gas, go to the next step.
6. From OFF position, push in gas control knob slightly and turn counterclockwise to the IGN position. See *Figure 45*. Push in and hold control knob for 5 seconds.  
**NOTE:** If you are running the heater for the first time, it will be necessary to press in the control knob for 30 seconds to allow air to bleed out of the gas piping.
7. With the control knob pushed in, push and release the piezo ignitor button to light the ODS pilot. The pilot is located on the right side of the heater, behind the front log and in front of the main burner. If piezo ignitor does not light the pilot, refer to “MATCH LIGHTING INSTRUCTIONS”, page 33.
8. Hold the control knob in for an additional 10 seconds to prevent the ODS pilot from shutting off the gas while the thermocouple is warming up.
9. Release the control knob.
  - If the knob does not pop out when released, stop and immediately call your service technician or gas supplier.
  - If the ODS pilot will not stay lit after several tries, push and turn the gas control knob clockwise to OFF and wait 15 seconds. Repeat steps 6 through 9.
10. Push in control knob and turn to desired setting (LOW or HIGH). The control knob must be set at either the low or high position, and the control knob will pop out when positioned correctly. Do not set the control knob at a position between LOW and HIGH. Refer to *Figures 46 and 47*.



*Figure 45 - IGN Position*



*Figure 46 - HIGH Position*



*Figure 47 - LOW Position*




**WARNING**

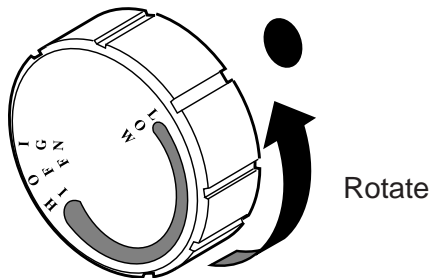
Wait 30 seconds before readjusting the heater when the control knob has been turned down to a lower setting.

## TO TURN OFF GAS TO HEATER

1. Turn control knob clockwise to OFF position to completely shut off the heater.
2. If applicable: Turn off all electric power to the heater.

## THERMOSTATIC CONTROL LIGHTING INSTRUCTIONS

1. STOP! Read the safety information .
2. Make sure the manual shutoff valve is fully open.
3. This heater is equipped with an ignition device (piezo) which automatically lights the pilot.
4. Refer to *Figure 45, page 30* for the location of the piezo ignitor and control knob. Turn control knob clockwise  to the OFF position.
5. Wait 5 minutes to clear out any gas. Then smell for gas, including near the floor. If you smell gas, STOP! Follow safety instructions under “WHAT TO DO IF YOU SMELL GAS”, page 29. If you do not smell gas, go to the next step.
6. Turn the gas control knob counterclockwise  to the IGN position. See *Figure 48*. Push in and hold control knob for 5 seconds.
7. With the control knob pushed in and held, push and release the piezo ignitor button to light the ODS pilot. The pilot is located on the right side of the heater, behind the front log and in front of the main burner. If piezo ignitor does not light the pilot, refer to “MATCH LIGHTING INSTRUCTIONS”, page 33.
8. Hold the control knob in for an additional 10 seconds to prevent the ODS pilot from shutting off the gas while the thermocouple is warming up.
9. Release the control knob.
  - If the knob does not pop out when released, stop and immediately call your service technician or gas supplier.
  - If the ODS pilot will not stay lit after several tries, push and turn the control knob clockwise  to OFF. Release and wait 15 seconds. Repeat steps 6 through 9.
10. Turn control knob to any position between LOW and HIGH. The knob position controls the thermostat temperature. Refer to *Figure 48*.
11. The heater is now in proper operation. The following procedure should be used to achieve thermostatic control of the desired room temperature.




**Figure 48 - Rotation of Control Knob**

- a. Operate unit at higher setting until desired room temperature is achieved.
- b. At the desired temperature, slowly turn the knob clockwise and stop rotating when flame disappears.
- c. Thermostat is now set to maintain the current room temperature.
- d. As the room temperature decreases, the thermostat valve will open to ignite the front and rear burner.
- e. When the temperature reaches its set point (knob position), the thermostat valve will again shut off the front and rear burner.
- f. This is the normal cycle of the heater.

**WARNING**




**Wait 30 seconds before readjusting the heater when the control knob has been turned down to a lower setting.**

## TO TURN OFF GAS TO HEATER

1. Turn control knob clockwise  to **OFF** position to completely shut off the heater.
2. If applicable: Turn off all electric power to the heater.

## OPERATING INSTRUCTIONS

### MILLI-VOLT CONTROL LIGHTING INSTRUCTIONS

1. STOP! Read the safety information label.
2. Make sure the manual shutoff valve is fully open.
3. This gas log set is equipped with an ignition device (piezo) which automatically lights the pilot. If piezo ignitor does not light the pilot, refer to instructions for "MATCH LIGHTING INSTRUCTIONS", page 33.
4. Turn gas control knob clockwise  to the OFF position, set the thermostat to the lowest setting and turn ON/OFF switch to OFF position.
5. Wait (5) minutes to clear out any gas. Then smell for gas, including near the floor. If you smell gas, STOP! Follow "B" in the safety information label. If you don't smell gas, go to next step.
6. From OFF position, turn the gas control knob counterclockwise  to IGN position. Push in control knob for 5 seconds.
7. With the control knob pushed in, push in and release the piezo ignitor button to light the pilot.
8. Continue pushing the control knob in for a further 60 seconds to prevent the flame detector from shutting off the gas while the probe is warming up. Release the control knob.
9. Turn gas control knob counterclockwise  to the ON position.
10. After the pilot has been lit for one minute, the burners can be turned on. Turn the ON/OFF switch to ON position or adjust thermostat to desired setting.
11. If the gas logs will not operate, follow the instructions "TO TURN OFF GAS TO APPLIANCE" below and call your service technician or gas supplier.

#### WARNING

Wait 30 seconds before readjusting the heater when the control knob has been turned down to a lower setting.

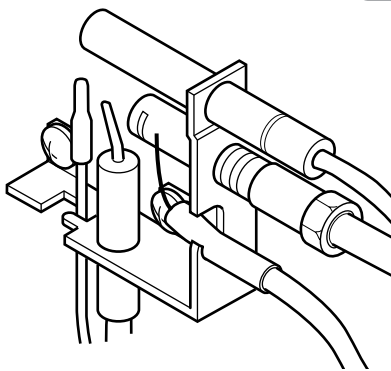


Figure 49 - Pilot

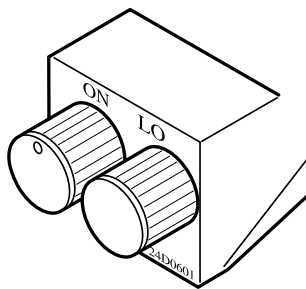


Figure 50 - Control Knobs

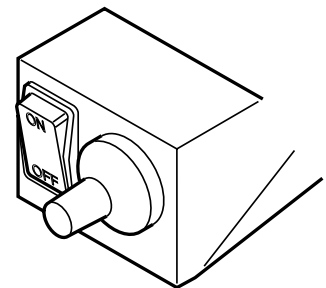



Figure 51 - Piezo

### TO TURN OFF GAS TO HEATER

1. Turn control knob clockwise  to **OFF** position to completely shut off the heater.
2. If applicable: Turn ON/OFF switch to OFF position and/or set thermostat (if present) to lowest setting.
3. If applicable: Turn off all electric power to the heater.

## MATCH LIGHTING INSTRUCTIONS

1. Remove any items necessary for easy access to the pilot (for example: logs, screens, etc.).
2. Follow appropriate lighting instructions found previously. Instead of pushing and releasing the piezo button, light a match and hold the flame to the end of the pilot and ignite the pilot.
3. After control knob has been released and pilot stays lit, reinstall any items that were removed for pilot access.
4. Call a qualified service technician for repair or replacement of the piezo ignitor.

## CLEANING AND SERVICING

Annual inspection and cleaning by your dealer or qualified service technician is recommended to prevent malfunction and/or sooting.

**WARNING**

Turn off heater and allow to cool before cleaning. Disconnect electrical power before cleaning or servicing.

Remove fireplace screen. Carefully lower screen from mounting lugs and set aside during cleaning. Refer to instruction manual for installation of screen. **DO NOT OPERATE THE UNIT WITH THE SCREEN REMOVED.**

Remove logs, handling carefully by holding gently at each end. Gloves are recommended to prevent skin irritation from ceramic fibers. If skin becomes irritated, wash gently with soap and water. Refer to manual for correct log placement.

### PERIODIC CLEANING - Refer to parts diagram for location of items discussed below.

- Do not use cleaning fluid to clean logs or any part of heater.
- Brush logs with soft bristle brush or vacuum with brush attachment.
- Vacuum loose particles and dust from the front and rear burner, control and piezo covers and grate weldment.
- Inspect and clean rear burner air intake holes. Remove lint or particles with vacuum, brush or pipe cleaners. Failure to keep air intake holes clean will result in sooting and poor combustion.
- External case should be dusted and wiped with a wet soapy cloth.

### ANNUAL CLEANING/INSPECTION - Refer to parts diagram for location of items discussed below.

- Inspect and clean rear burner air intake holes. Remove lint or particles with vacuum, brush or pipe cleaners. Failure to keep air intake holes clean will result in sooting and poor combustion.
- Inspect and clean all burner ports.
- Inspect ODS pilot for operation and accumulation of lint at air intake holes.
- Verify flame pattern and log placement for proper operation.
- Verify smooth and responsive ignition of main burner and rear burner.

---

## **BLOWER AND OTHER OPTIONAL EQUIPMENT**

---

### **OPTIONAL EQUIPMENT**

#### **FORCED AIR KIT**

If you are installing the forced air kit, Model BLO24 or Model BLO, see the installation instructions provided with the kit for electrical wiring requirements or the blower installation section. Models DFX24 and DBX24 use blower model BLO24. Model DFX32 uses blower model BLO. The firebox must be connected to main power supply at time of firebox installation. The blower must be installed prior to the installation of the unvented heater. The electrical connections must be made before the firebox is framed and enclosed in the finished walls.

#### **BRASS LOUVERS**

Optional brass louvers may be installed in place of the factory installed black louvers. Refer to installation instructions provided with the brass or chrome louvers.

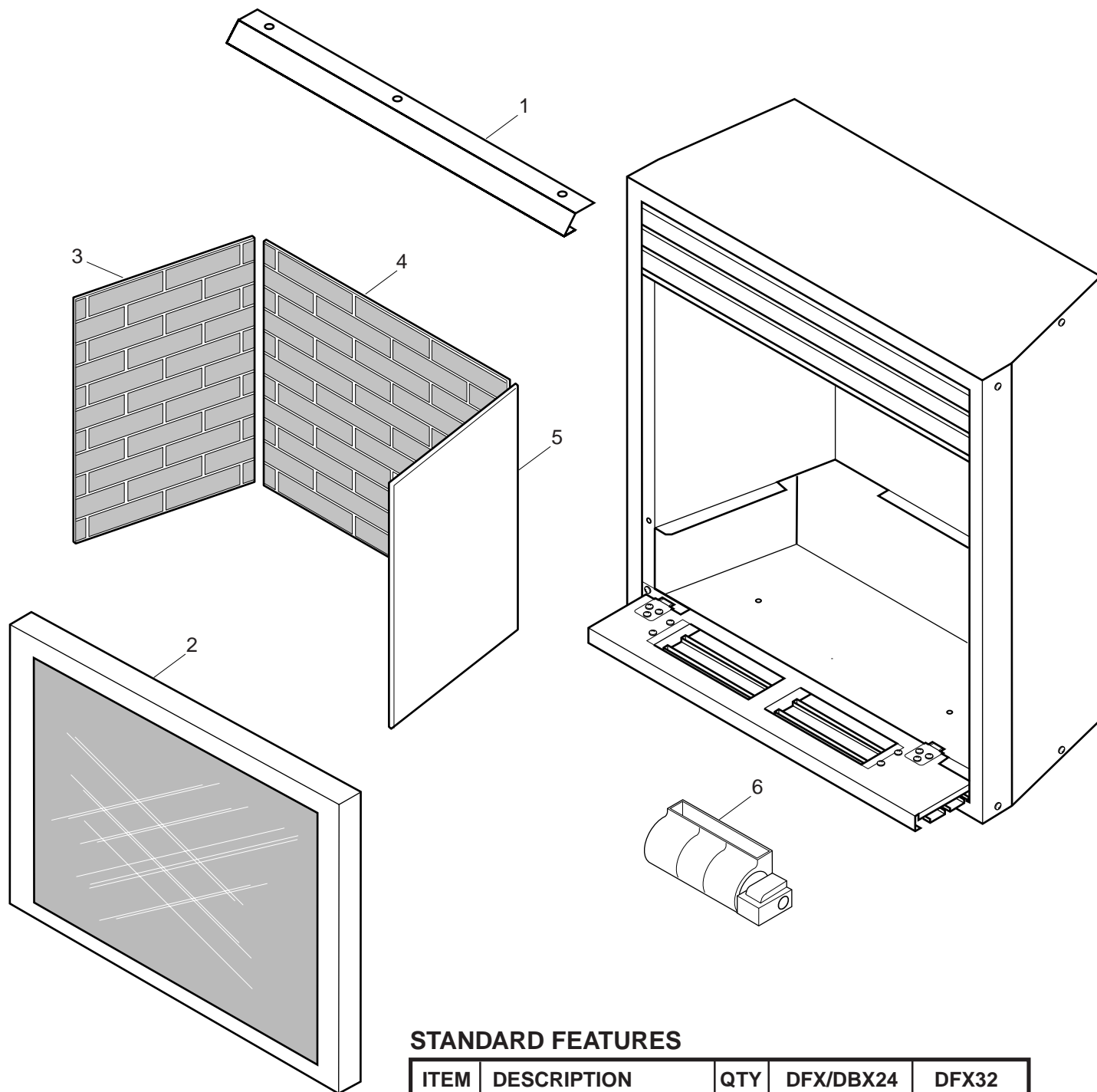
#### **FIREBRICKS**

Optional firebrick kits can be installed. Refer to installation instructions provided with kit or see page 11.

#### **CAUTION**

**Electrical connections should only be performed by a qualified, licensed electrician, main power must be off when connecting to main electrical power supply or performing service.**

# ILLUSTRATED PARTS BREAKDOWN FOR CABINET ACCESSORIES



## STANDARD FEATURES

ITEM	DESCRIPTION	QTY	DFX/DBX24	DFX32
1	Canopy	1	33D0015	33D1022
2	Screen Assembly	1	33D0050	33D1066
3	Left Firebrick (Optional)	1	33D0202	33D1044
4	Center Firebrick (Optional)	1	33D0200	33D1042
5	Right Firebrick (Optional)	1	33D0201	33D1043
6	Blower (Optional)	1	BLO-24	BLO

# ILLUSTRATED PARTS BREAKDOWN

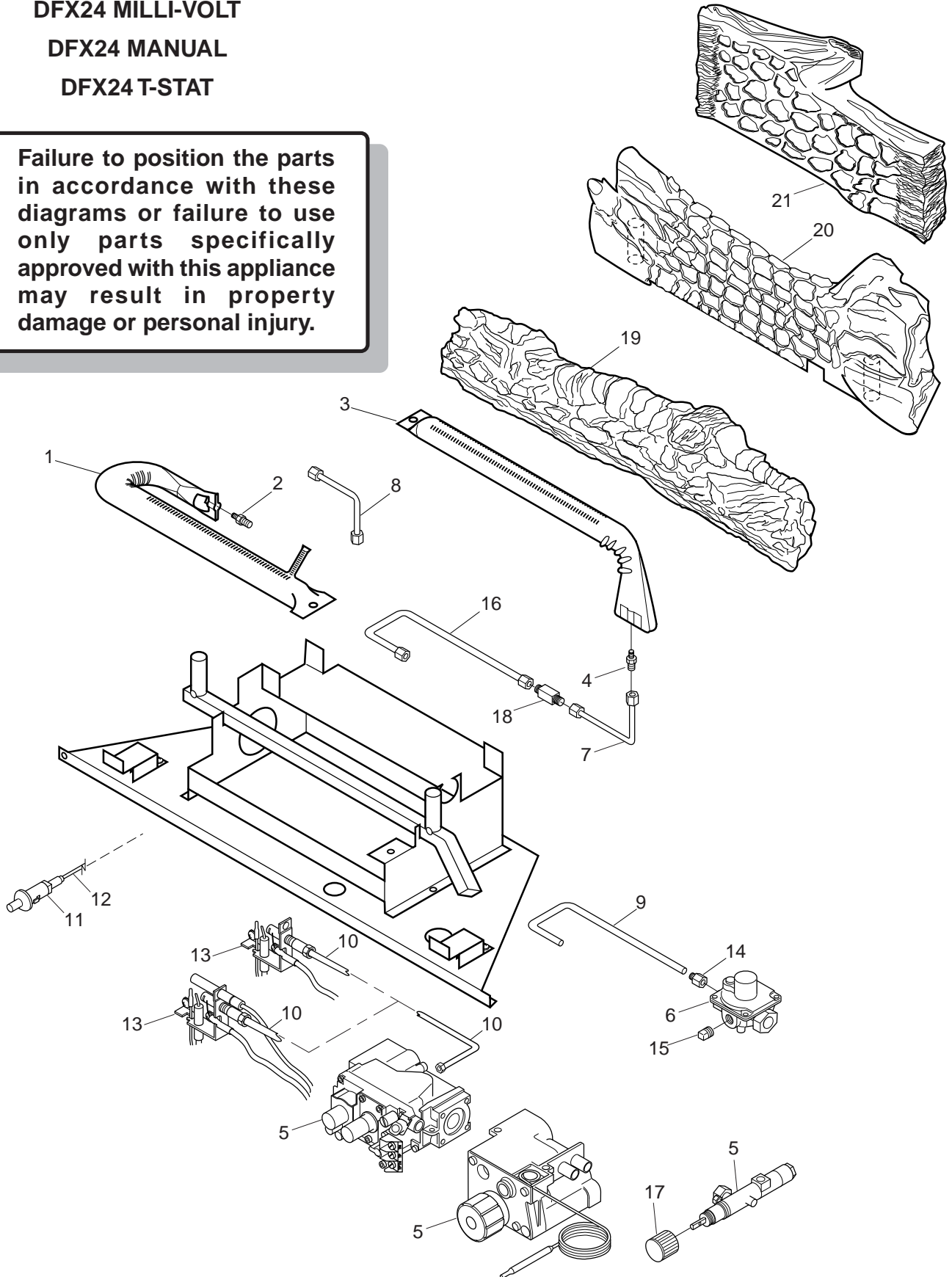
DFX24 MILLI-VOLT

DFX24 MANUAL

DFX24 T-STAT

**WARNING**

Failure to position the parts in accordance with these diagrams or failure to use only parts specifically approved with this appliance may result in property damage or personal injury.





## REPLACEMENT PARTS LIST

**REPLACEMENT PARTS ARE AVAILABLE THROUGH YOUR RETAILER.**

ITEM	DESCRIPTION	DFX24 MILLIVOLT			DFX24 MANUAL			DFX24 T-STAT		
		QTY	NATURAL	PROPANE	QTY	NATURAL	PROPANE	QTY	NATURAL	PROPANE
1	Front Burner	1	33D0206	33D0206	1	33D0206	33D0206	1	33D0206	33D0206
2	Front Injector	1	33D0207	33D0209	1	33D0207	33D0209	1	33D0207	33D0209
3	Rear Burner	1	33D0262	33D0275	1	33D0262	33D0275	1	33D0262	33D0275
4	Rear Injector	1	33D0055	33D0209	1	33D0207	33D0209	1	33D0207	33D0209
5	Milli-Volt Valve	1	14D0467	14D0468						
5	Manual Control Valve	1			1	00K0910	00K0910			
5	T-stat Control Valve							1	11V0701	11V0701
6	Pressure Valve Regulator	1	14D0469	14D0469	1	18D0351	18D0352	1	18D0351	18D0352
7	Rear Burner Valve Tube, 1/4	1	33D0256	33D0256	1	33D0278	33D0278	1	33D0269	33D0269
8	Front Bruner Valve Tube, 1/4	1	33D0257	33D0257	1	33D0279	33D0279	1	33D0268	33D0268
9	Regulator Valve Tube, 5/16				1	33D0276	33D0276			
10	ODS Pilot Valve Tube, 3/16	1	33D0252	33D0254	1	33D0277	33D0284	1	33D0266	33D0285
11	Piezo Ignitor	1	14D0503	14D0503	1	00F0011	00F0011	1	18D0401	18D0401
12	Piezo Wire	1	00K0632	00K0632	1	00K0632	00K0632	1	00K0632	00K0632
13	ODS Pilot Assembly	1	14D0473	14D0474	1	26D2529	26D2530	1	26D2529	26D2530
14	Tube Fitting, 3/8 x 5/16				1	11V0313	11V0313			
15	NPT Pipe Plug, 1/8				1	00F0092	00F0092	1	00F0092	00F0092
16	Tube Valve to Tee	1	33D0255	33D0255				1	33D0267	33D0267
17	Control Knob				1	18D0602	18D0602			
18	Tube Tee, 1/4	1	00F0474	00F0474				1	00F0474	00F0474
<b>LOG SET</b>										
19	#1 Front Log	1	33D0213	33D0213	1	33D0213	33D0213	1	33D0213	33D0213
20	#2 Middle Log	1	33D0211	33D0211	1	33D0211	33D0211	1	33D0211	33D0211
21	#3 Rear Log	1	33D0212	33D0212	1	33D0212	33D0212	1	33D0212	33D0212
<b>PARTS AVAILABLE, NOT SHOWN</b>										
	Tube Nut, 1/4	4	00F0079	00F0079	4	00F0079	00F0079	4	00F0079	00F0079
	Tube Ferrule, 1/4	4	00F0080	00F0080	4	00F0080	00F0080	4	00F0080	00F0080
	Tube Nut, 3/16	2	00F0077	00F0077	2	00F0077	00F0077	1	00F0077	00F0077
	Tube Ferrule, 3/16	2	00F0078	00F0078	2	00F0078	00F0078	2	00F0078	00F0078
	Tube Nut, 5/16				2	00K0917	00K0917			
	Tube Ferrule, 5/16				2	00K0918	00K0918			
	Piezo Nut				1	00F0587	00F0587			
	Piezo Kit							1	18D0402	18D0402
	NPT Tube Fitting, 3/8 x 1 1/2							1	18D0310	18D0310
	Flex Tube with Fittings	1	20H0022	20H0022	1	20H0022	20H0022	1	20H0022	20H0022
	Modulating Screw (Min Flow)							1	945624	045618
	Reverse Flare Nut, 3/16 Tube							1	11V0314	11V0314
	NPT Tube Fitting, 3/8 x 1/4	1	11V3012	11V3012				1	11V0312	11V0312



# ILLUSTRATED PARTS BREAKDOWN

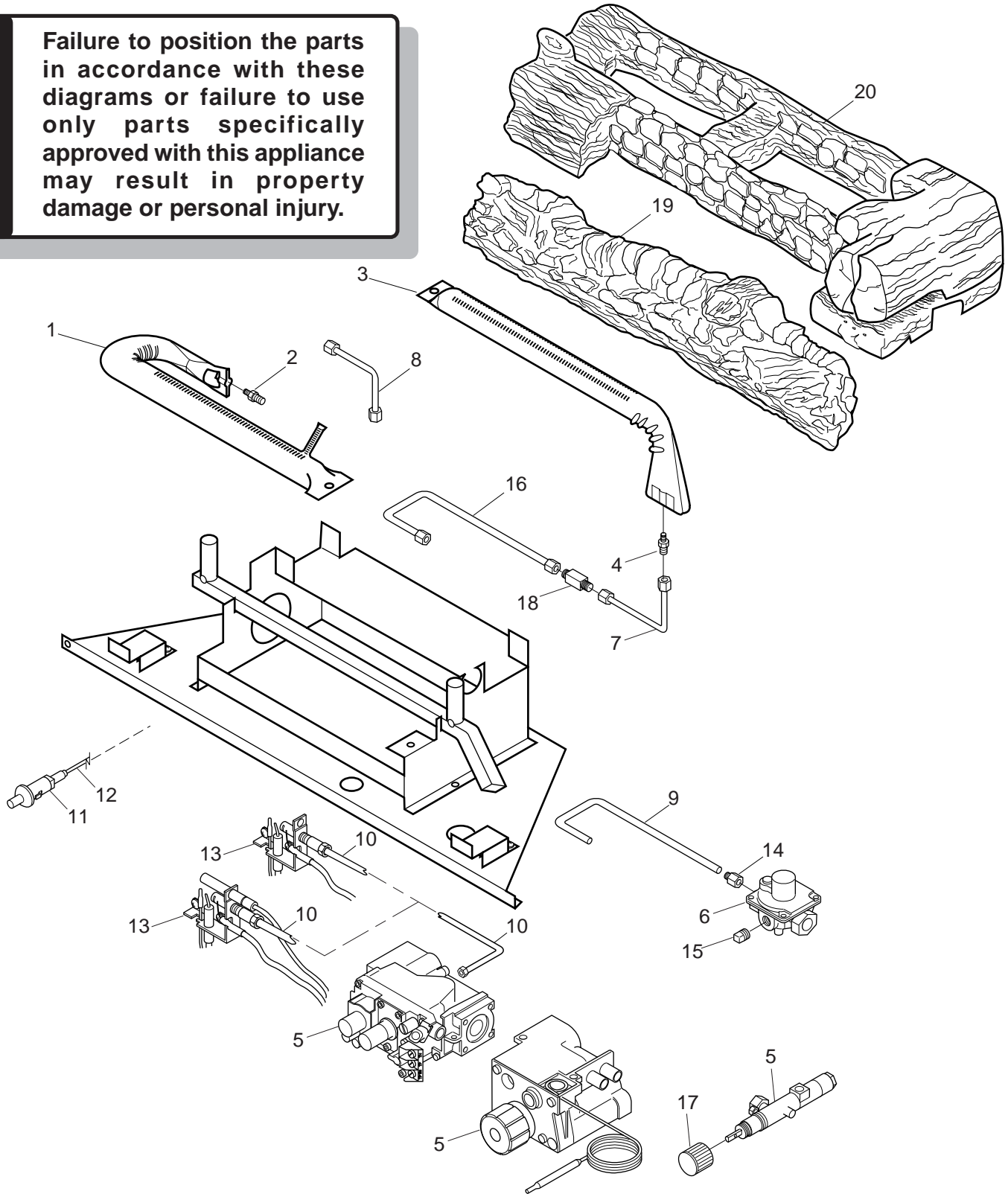
DFX32 MILLI-VOLT

DFX32 MANUAL

DFX32 T-STAT

**WARNING**

Failure to position the parts in accordance with these diagrams or failure to use only parts specifically approved with this appliance may result in property damage or personal injury.



## REPLACEMENT PARTS LIST

**REPLACEMENT PARTS ARE AVAILABLE THROUGH YOUR RETAILER.**

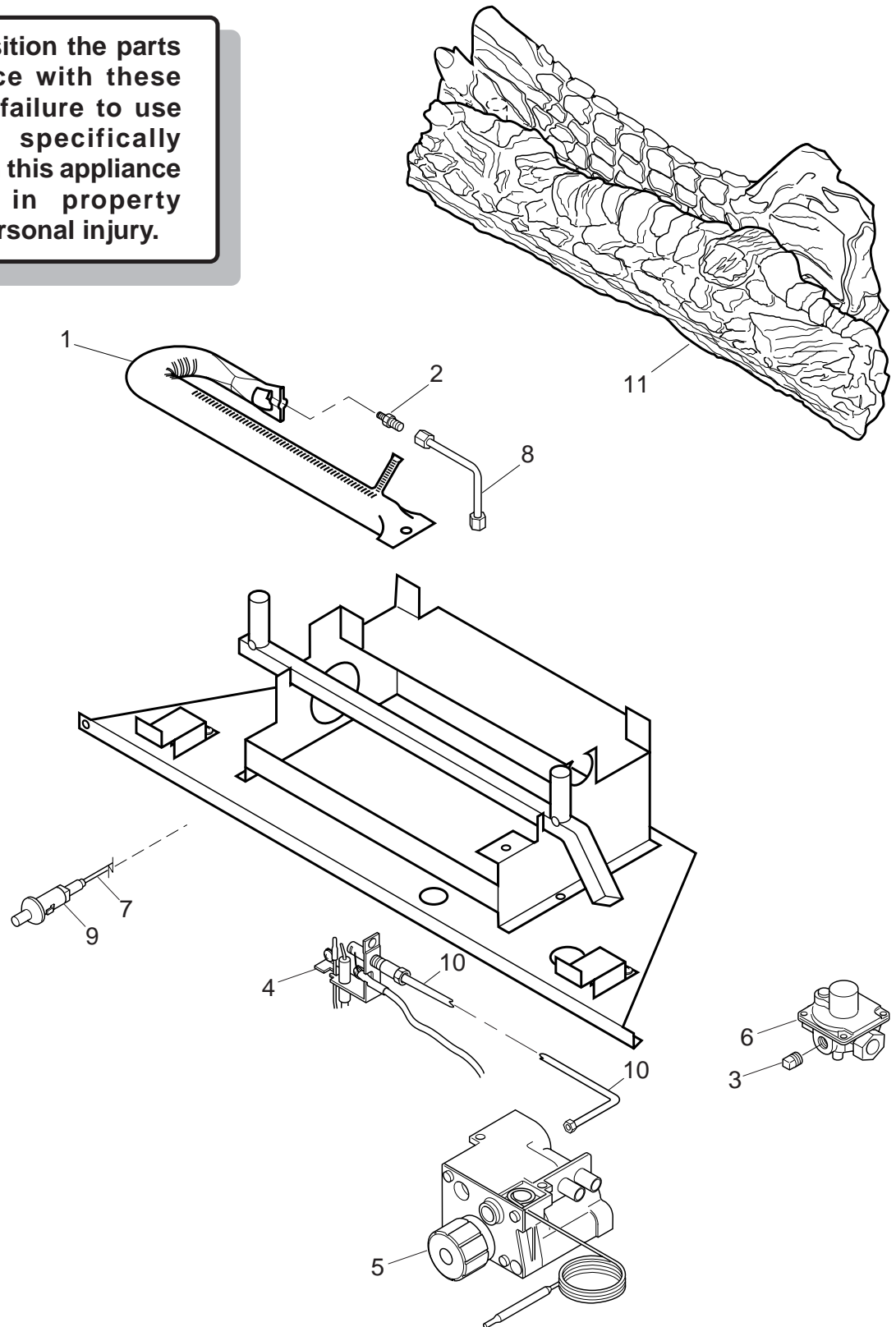
ITEM	DESCRIPTION	DFX32 MILLIVOLT			DFX32 MANUAL			DFX32 T-STAT		
		QTY	NATURAL	PROPANE	QTY	NATURAL	PROPANE	QTY	NATURAL	PROPANE
1	Front Burner	1	33D1093	33D1068	1	33D1093	33D1068	1	33D1093	33D1068
2	Front Injector	1	33D1069	14D0571	1	33D1069	14D0571	1	33D0069	14D0571
3	Rear Burner	1	14D2255	14D9055	1	14D2255	14D9055	1	14D2255	14D9055
4	Rear Injector	1	14D0562	14D0563	1	14D0562	14D0563	1	14D0562	14D0563
5	Milli-Volt Valve	1	14D0467	14D0468						
5	Manual Control Valve	1			1	00K0910	00K0910			
5	T-stat Control Valve							1	11V0701	11V0701
6	Pressure Valve Regulator	1	14D0469	14D0469	1	18D0351	18D0352	1	18D0351	18D0352
7	Rear Burner Valve Tube, 1/4	1	33D1051	33D1051	1	33D1059	33D1059	1	33D1051	33D1051
8	Front Bruner Valve Tube, 1/4	1	33D1052	33D1052	1	33D1060	33D1060	1	33D1052	33D1052
9	Regulator Valve Tube, 5/16				1	33D0276	33D0276			
10	ODS Pilot Valve Tube, 3/16	1	33D1047/48	33D1049	1	33D1058	33D1061	1	33D1067	33D1062
11	Piezo Ignitor	1	14D0503	14D0503	1	00F0011	00F0011	1	18D0401	18D0401
12	Piezo Wire	1	00K0632	00K0632	1	00K0632	00K0632	1	00K0632	00K0632
13	ODS Pilot Assembly	1	14D0473	14D0474	1	26D2529	26D2530	1	26D2529	26D2530
14	Tube Fitting, 3/8 x 5/16				1	11V0313	11V0313			
15	NPT Pipe Plug, 1/8				1	00F0092	00F0092	1	00F0092	00F0092
16	Tube Valve to Tee	1	33D0255	33D0255				1	33D0267	33D0267
17	Control Knob				1	18D0602	18D0602			
18	Tube Tee, 1/4	1	00F0474	00F0474				1	00F0474	00F0474
<b>LOG SET</b>										
19	#1 Front Log	1	33D1074	33D1074	1	33D1074	33D1074	1	33D1074	33D1074
20	#2 Middle Log	1	33D1075	33D1075	1	33D1075	33D1075	1	33D1075	33D1075
<b>PARTS AVAILABLE, NOT SHOWN</b>										
	Tube Nut, 1/4	4	00F0079	00F0079	4	00F0079	00F0079	4	00F0079	00F0079
	Tube Ferrule, 1/4	4	00F0080	00F0080	4	00F0080	00F0080	4	00F0080	00F0080
	Tube Nut, 3/16	2	00F0077	00F0077	2	00F0077	00F0077	1	00F0077	00F0077
	Tube Ferrule, 3/16	2	00F0078	00F0078	2	00F0078	00F0078	2	00F0078	00F0078
	Tube Nut, 5/16				2	00K0917	00K0917			
	Tube Ferrule, 5/16				2	00K0918	00K0918			
	Piezo Nut				1	00F0587	00F0587			
	Piezo Kit							1	18D0402	18D0402
	NPT Tube Fitting, 3/8 x 1 1/2							1	18D0310	18D0310
	Flex Tube with Fittings	1	20H0022	20H0022	1	20H0022	20H0022	1	20H0022	20H0022
	Modulating Screw (Min Flow)							1	945624	045618
	Reverse Flare Nut, 3/16 Tube							1	11V0314	11V0314
	NPT Tube Fitting, 3/8 x 1/4	1	11V3012	11V3012				1	11V0312	11V0312

# ILLUSTRATED PARTS BREAKDOWN

## DBX24 T-STAT

**WARNING**

Failure to position the parts in accordance with these diagrams or failure to use only parts specifically approved with this appliance may result in property damage or personal injury.



## REPLACEMENT PARTS LIST

**REPLACEMENT PARTS ARE AVAILABLE THROUGH YOUR RETAILER.**

ITEM	DESCRIPTION	DBX24 T-STAT		
		QTY	NATURAL	PROPANE
1	Burner	1	33D0263	33D0206
2	Injector	1	33D0280	33D0281
3	NPT Pipe Plug, 1/8	1	00F0092	00F0092
4	ODS Pilot Assembly	1	26D2529	26D2530
5	T-stat Control Valve	1	11V0701	11V0701
6	Pressure Valve Regulator	1	18D0351	18D0352
7	Piezo Wire	1	00K0632	00K0632
8	Bruner Valve Tube, 1/4	1	33D0065	33D0065
9	Piezo Ignitor	1	18D0401	18D0401
10	ODS Pilot Valve Tube, 3/16	1	33D0043	33D0043
<b>LOG SET</b>				
11	#1 Front Log	1	33D0066	33D0066
<b>PARTS AVAILABLE, NOT SHOWN</b>				
	Tube Nut, 1/4	2	00F0079	00F0079
	Tube Ferrule, 1/4	2	00F0080	00F0080
	Tube Nut, 3/16	1	00F0077	00F0077
	Tube Ferrule, 3/16	2	00F0078	00F0078
	Piezo Kit	1	18D0402	18D0402
	NPT Tube Fitting, 3/8 x 1 1/2	1	26D2529	26D2530
	Flex Tube with Fittings	1	20H0022	20H0022
	Modulating Screw (Min Flow)	1	972057	972057
	Reverse Flare Nut, 3/16 Tube	1	11V0314	11V0314
	NPT Tube Fitting, 3/8 x 1/4	1	11V0312	11V0312

## TROUBLESHOOTING

### WARNING

Turn appliance OFF and allow to cool before servicing. Only a qualified service person should service and repair the heater.

*Note: All troubleshooting items are listed in order of operation.*

OBSERVED PROBLEM	POSSIBLE CAUSE	REMEDY
When ignitor button is pressed, there is no spark at ODS/pilot.	<ol style="list-style-type: none"> <li>1. Ignitor electrode positioned wrong.</li> <li>2. Ignitor electrode is broken.</li> <li>3. Ignitor electrode not connected to ignitor cable.</li> <li>4. Ignitor cable pinched or wet. Keep ignitor cable dry.</li> <li>5. Broken ignitor cable.</li> <li>6. Bad piezo ignitor.</li> </ol>	<ol style="list-style-type: none"> <li>1. Replace ignitor.</li> <li>2. Replace ignitor.</li> <li>3. Reconnect ignitor cable.</li> <li>4. Free ignitor cable if pinched by any metal or tubing.</li> <li>5. Replace ignitor cable.</li> <li>6. Replace piezo ignitor.</li> </ol>
Appliance produces unwanted odors.	<ol style="list-style-type: none"> <li>1. Appliance burning vapors from paint, hair spray, glues, etc.</li> <li>2. Gas leak.</li> <li>3. Initial burn off.</li> </ol>	<ol style="list-style-type: none"> <li>1. Ventilate room. Stop using odor causing products while heater is running.</li> <li>2. Locate and correct all leaks.</li> <li>3. Ventilate room and turn unit on high until odor is gone.</li> </ol>
Appliance shuts off during use.	<ol style="list-style-type: none"> <li>1. Not enough fresh air is available for ODS/ pilot to operate.</li> <li>2. Low line pressure.</li> <li>3. ODS/pilot is partially clogged.</li> <li>4. Defective Thermopile</li> </ol>	<ol style="list-style-type: none"> <li>1. Open window and/or door for ventilation.</li> <li>2. Contact local gas company.</li> <li>3. Clean ODS/pilot.</li> <li>4. Check pilot flame, check wire connections, check output, should be 325 millivolts across TH/TP and TP Terminals with ON/OFF switches off.</li> </ol>
Gas odor even when control knob is in OFF position.	<ol style="list-style-type: none"> <li>1. Gas leak.</li> <li>2. Control valve defective.</li> </ol>	<ol style="list-style-type: none"> <li>1. Locate and correct all leaks.</li> <li>2. Replace control valve.</li> </ol>
When ignitor button is pressed, there is spark at ODS pilot, but no ignition.	<ol style="list-style-type: none"> <li>1. Gas supply turned off or manual shutoff valve closed.</li> <li>2. Control knob not in PILOT position.</li> <li>3. Control knob not pressed in while in PILOT position.</li> <li>4. Air in gas lines when installed.</li> <li>5. ODS/pilot is clogged.</li> <li>6. Gas regulator setting is not correct.</li> </ol>	<ol style="list-style-type: none"> <li>1. Turn on gas supply or open manual shutoff valve.</li> <li>2. Turn control knob to PILOT position.</li> <li>3. Press in control knob while in PILOT position.</li> <li>4. Continue holding down control knob. Repeat igniting operation until air is removed.</li> <li>5. Replace ODS/pilot assembly or get it serviced.</li> <li>6. Replace gas regulator</li> </ol>
ODS/pilot lights, but flame goes out when control knob is released.	<ol style="list-style-type: none"> <li>1. Control knob not fully pressed in.</li> <li>2. Control knob not pressed in long enough.</li> <li>3. Manual shutoff valve not fully open.</li> </ol>	<ol style="list-style-type: none"> <li>1. Press in control knob fully.</li> <li>2. After ODS/pilot lights, keep control knob pressed in for 30 seconds.</li> <li>3. Fully open manual shutoff valve.</li> </ol>

OBSERVED PROBLEM	POSSIBLE CAUSE	REMEDY
	<ol style="list-style-type: none"> <li>4. Thermocouple connection loose at control valve.</li> <li>5. Pilot flame not touching thermocouple, which allows thermocouple to cool, causing pilot flame to go out. This problem could be caused by either low gas pressure, or a dirty or partially clogged ODS/pilot.</li> <li>6. Thermocouple damaged.</li> <li>7. Control valve damaged.</li> </ol>	<ol style="list-style-type: none"> <li>4. Hand tighten until snug, then tighten 1/4 turn more.</li> <li>5. Contact local gas company.</li> <li>6. Replace thermocouple.</li> <li>7. Replace control valve.</li> </ol>
<b>One or both burners do not light after ODS/pilot is lit.</b>	<ol style="list-style-type: none"> <li>1. Burner orifice is clogged.</li> <li>2. Burner orifice diameter is too small.</li> <li>3. Inlet gas pressure is too low.</li> </ol>	<ol style="list-style-type: none"> <li>1. Clean burner or replace burner orifice.</li> <li>2. Replace burner orifice.</li> <li>3. Contact qualified service person.</li> </ol>
<b>Burner backfires during combustion.</b>	<ol style="list-style-type: none"> <li>1. Manifold pressure is too low.</li> <li>2. Burner orifice is clogged.</li> </ol>	<ol style="list-style-type: none"> <li>1. Contact local gas company.</li> <li>2. Clean burner or replace burner orifice.</li> </ol>
<b>Slight smoke or odor during initial operation.</b>	<ol style="list-style-type: none"> <li>1. Burner orifice is clogged or damaged.</li> <li>2. Burner is damaged.</li> <li>3. Gas regulator defective.</li> </ol>	<ol style="list-style-type: none"> <li>1. Clean burner or replace burner orifice.</li> <li>2. Replace burner.</li> <li>3. Replace gas regulator.</li> </ol>
<b>Logs appear to smoke after initial operation.</b>	<ol style="list-style-type: none"> <li>1. Vapors from paint or curing process of logs.</li> </ol>	<ol style="list-style-type: none"> <li>1. Problem will stop after a few hours of operation. Run the heater with the damper open if you have one, or open a window for the first few hours.</li> <li>2. Log heater is intended to be smokeless. Turn OFF heater and call qualified service person.</li> </ol>
<b>Heater produces a whistling noise when burner is lit.</b>	<ol style="list-style-type: none"> <li>1. Turning control knob to HIGH position when burner is cold.</li> <li>2. Air in gas line.</li> <li>3. Dirty or partially clogged burners orifice.</li> </ol>	<ol style="list-style-type: none"> <li>1. Turn control knob to LOW position and let warm up for a minute.</li> <li>2. Operate burner until air is removed from line. Have gas line checked by local gas company.</li> <li>3. Clean burner or replace burner orifice.</li> </ol>
<b>No gas to pilot.</b>	<ol style="list-style-type: none"> <li>1. LP-regulator shut down due to inlet pressure too high.</li> </ol>	<ol style="list-style-type: none"> <li>1. Verify LP tank regulator is installed and set at 11" to 13" w.c.</li> <li>2. Replace regulator on heater.</li> </ol>

**WARNING**

**If the gas quality is bad, your pilot may not stay lit, the burners may produce soot and the heater may backfire when lit. If the gas quality or pressure is low, contact your local gas supplier immediately.**

# MONESSEN HEARTH SYSTEMS

## LIMITED LIFETIME WARRANTY POLICY

### LIFETIME WARRANTY

The following components are warranted for life to the original owner, subject to proof of purchase: Firebox, Combustion Chamber, Heat Exchanger, Grate and Stainless Steel Burners.

### FIVE YEAR WARRANTY

The following components are warranted for 5 years to the original owner, subject of proof of purchase: Ceramic Fiber Logs, Catalytic Filter and Aluminized Burners.

### BASIC WARRANTY

Monessen Hearth Systems (MHS) warrants the components and materials in your gas appliance to be free from manufacturing and material defects for a period of one year from date of installation. After installation, if any of the components manufactured by MHS in the appliance are found to be defective in materials or workmanship, MHS will, at its option, replace or repair the defective components at no charge to the original owner. MHS will also pay for reasonable labor costs incurred in replacing or repairing such components for a period of one year from the date of installation. Any products presented for warranty repair must be accompanied by a dated proof of purchase.

This Limited Warranty will be void if the appliance is not installed by a qualified installer in accordance with the installation instructions. The Limited Lifetime Warranty will also be void if the appliance is not operated and maintained according to the operating instructions supplied with the appliance, and does not extend to (1) firebox/burner assembly damage by accident, neglect, misuse, abuse, alteration, negligence of others, including the installation thereof by unqualified installers, (2) the costs of removal, reinstallation or transportation of defective parts on the appliance, or (3) incidental or consequential damage. All service work must be performed by an authorized service representative.

This warranty is expressly in lieu of other warranties, express or implied, including the warranty of merchantability of fitness for purpose and of all other obligations or liabilities. Monessen Hearth Systems, Inc. does not assume for it any other obligations or liability in connection with the sale or use of the appliance. In states that do not allow limitations on how long an implied warranty lasts, or do not allow exclusion of indirect damages, those limitations of exclusions may not apply to you. You may also have additional rights not covered in this Limited Warranty.

MHS reserves the right to investigate any and all claims against the Limited Warranty and decide upon method of settlement.

For information about this warranty, contact:

**Technical Services  
Monessen Hearth Systems  
149 Cleveland Drive  
Paris, Kentucky 40361**